
	<b>GREEN METER ADAPTER (GMA) FOR CUSTOMER GENERATION</b>		<b>094684</b>
	<b>Asset Type:</b> Electric Distribution <b>Issued by:</b> Daniel Jantz (DWJ7)		<b>Function:</b> Design, Estimating, and Field Personnel <b>Date:</b> 3/25/2022
<b>Rev. #00:</b> This new document replaces bulletin TD-7001B-007, Rev. #02. For a description of the changes, see Page 15.			

**Purpose and Scope**

This document provides information about the PG&E Green Meter Adapter (GMA) program that allows the installation of an electric meter socket adapter that will accept a wired connection directly from a residential customer’s Photo Voltaic (PV) solar generation system. The adapter is installed between the PG&E meter and the meter socket in the electric panel. Through this adapter, the solar system is connected to the load side of the PG&E meter and the supply side of the customer’s main breaker.

The GMA is an alternative to upgrading an electric panel and service which may save time and additional cost.

References	Location	Document
<a href="#">Electric and Gas Service Requirements (Greenbook)</a>	.....	<a href="#">TD-7001M</a>
<a href="#">Distribution Interconnection Handbook</a>	.....	<a href="#">TD-2306M</a>
<a href="#">Green Meter Adapter (GMA) Installation</a>	.....	<a href="#">TD-6259P-01</a>

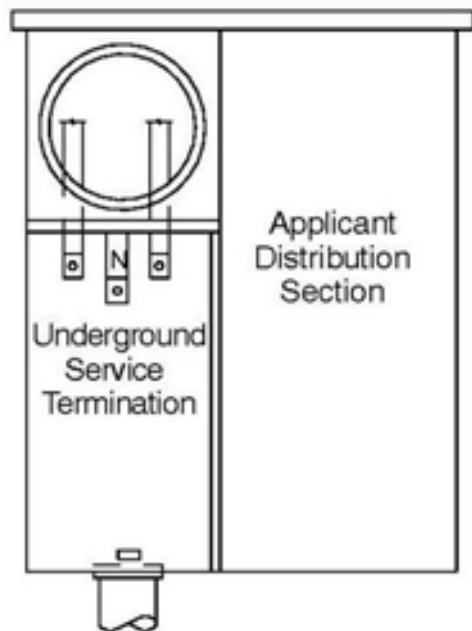
**General Information**

1. The review and approval of a GMA are at the discretion of the PG&E Meter Engineering and Field Metering personnel. When a GMA cannot be installed, an upgrade to the electrical panel and service may be required to support the customer’s generating system. The GMA is not allowed on electric meter panels with the following conditions or location.
  - A Have deteriorated parts.
  - B Is rated above 125 amps.
  - C Gas meter and working space clearances are not met.
  - D Located on poles or inside cabinets.
  - E Has an overhead to underground service adapter or another meter adapter already installed.
  - F Is a stand-alone meter socket, as shown in Figure 2 on Page 2.
  - G Where the GMA and/or wires cannot be routed and terminated appropriately.
  - H There are protruding obstructions on the front or around the meter panel.

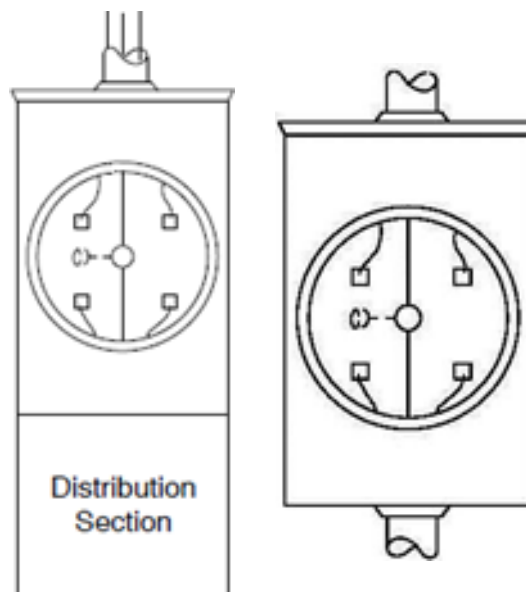
**Eligibility Requirements**

2. If you are a PG&E residential customer, you may request the installation of a GMA if all of the requirements listed below are met.
3. A self-contained electric meter panel not exceeding a 125 amp rating, as determined by PG&E, and an underground single phase 120/240 volt electric service is installed.
4. The main breaker and meter socket are contained in the same underground electrical panel as shown in Figure 1.  
**Note:** Combination Meter panels that are manufactured to accept either an underground or overhead service cables may be accepted.
5. A GMA is not allowed on Individual Meter Sockets, overhead meter panels, or meter panels without service disconnects. See Figure 2.

## Green Meter Adapter (GMA) for Customer Generation



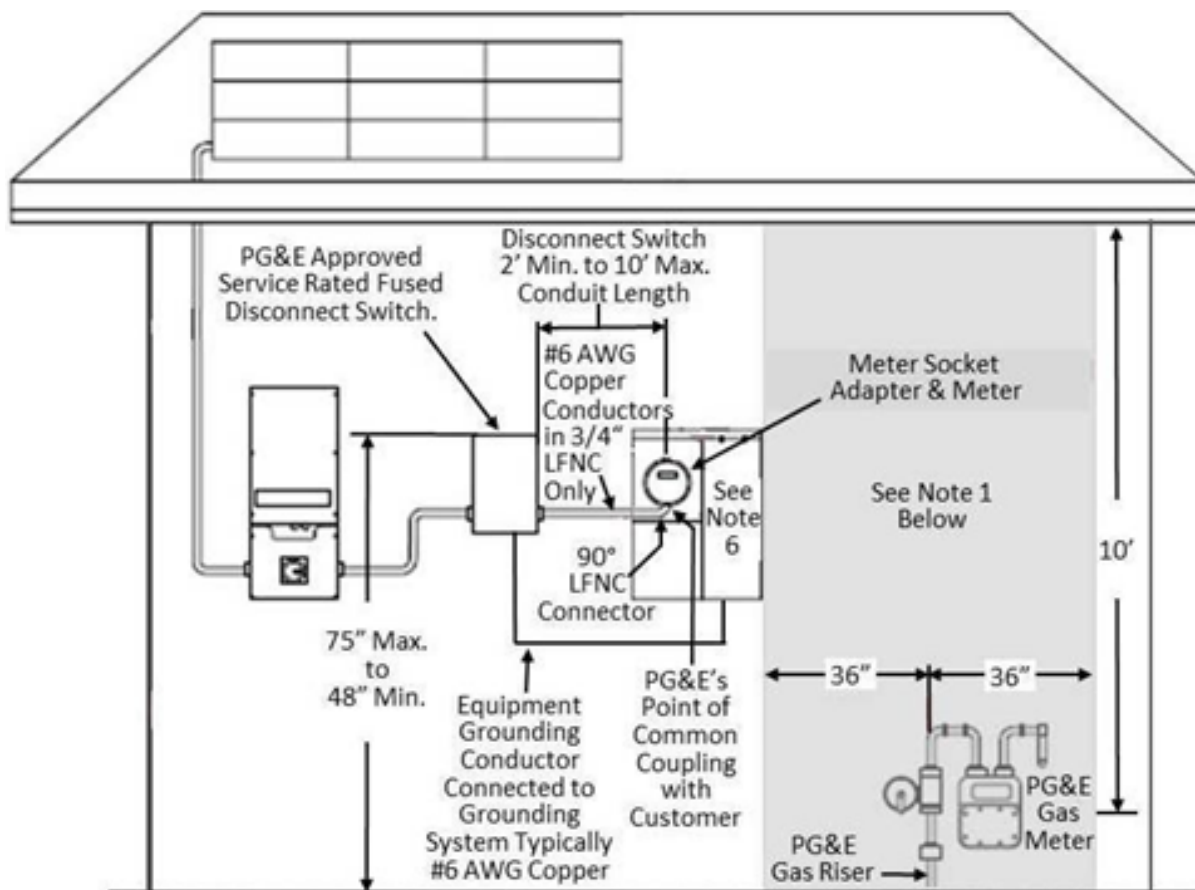
**Figure 1**  
Underground Electric Meter Panel with  
Breaker Section



**Figure 2**  
Not Allowed – Overhead Meter  
Panel or Individual Meter Socket  
without Breaker Section

6. An underground electric meter panel that meets all PG&E requirements and passes an initial review before the installation. The panel must also pass an on-site inspection by PG&E personnel. If the panel does not pass the initial review, or inspection, the GMA cannot be installed.
7. The customer's solar generating system, including an energy storage system if installed, connected to the GMA, will have no more than a maximum rating of 14.0 kilowatts (kW) at 240 volts (V) and does not produce a total of more than 60 amps.
8. The local Authority Having Jurisdiction (AHJ) has issued a permit for the installation of your generation system and the line side connection to the GMA. Some AHJ's may not approve this type of interconnection.
9. Any existing customer generation and energy storage sources on the property that are interconnected with the PG&E service are identified on the EGI application and submitted drawings. This could be in the customer distribution section (i.e., breaker or line/supply side connection) of the main panel or in a sub-panel. A GMA might be allowed with other interconnected sources if all PG&E requirements are met, and approved signage is affixed to the point(s) of interconnection.
10. All customer equipment must meet the PG&E gas and electric meter clearances shown in Figure 3 and in the PG&E [Electric and Gas Service Requirements \(Greenbook\)](#).

## Green Meter Adapter (GMA) for Customer Generation



**Figure 3**  
**PG&E Gas & Electric Clearances and GMA**  
**Requirements**

### Notes in reference to Figure 3:

A Applicants must not install any electrical devices or generation equipment, including wires, cables, enclosures, bond wires, clamps, or ground rods within the shaded area around the gas meter.

Exception: A straight, solid, and continuous metallic conduit without couplings, joints, or connections is allowed to run completely through the shaded area at 6 feet or higher above the gas meter regulator vent. The continuous conduit may have electric wiring inside. Refer to [Greenbook](#) Figure 2-19 on page 2-32 and the Figure notes.

B Minimum requirements of 36" deep x 30" wide x 75" high, clear and level working space are required in front of the meter panel.

C A GMA is only allowed to be installed in meter panels with a maximum rating of 125 amps or less and must not be installed in a meter panel with a greater rating, as determined by PG&E.

D The maximum combined current allowed to be connected to the GMA from all alternate (non-utility) energy sources is 60 amps.

E The wire between the fused disconnect switch and the GMA must be insulated copper wire, sized at AWG 6 gauge, and rated for 90° C. Other wire sizes, types, or rating will not be accepted.

F Bond an Equipment Grounding Conductor from the Disconnect Switch and connect to the Service Grounding System. Typically, #6 AWG Copper, bare.

### Technical Requirements

11. PG&E will own, supply, and install the GMA.
12. Only qualified PG&E personnel may install the GMA.

## Green Meter Adapter (GMA) for Customer Generation

---

13. Customer owned and PG&E non-approved adapters will not be allowed.
14. The customer will own, install, and maintain the conduit, connector fittings, wires, and fused disconnect switch. The following specified equipment is required. Substitutions are not acceptable.
15. A PG&E approved fused AC disconnect switch is installed between 2 feet to 10 feet from the meter panel. The disconnect switch must meet all of the PG&E requirements as described in Numbered Document [060559 Disconnect Switches for Interconnection With Small Power Producers and Cogenerators](#).
16. Install 3/4-inch diameter, UL Listed Liquidtight Flexible Nonmetallic Conduit (LFNC) between the GMA and the fused disconnect switch.
  - A The conduit length shall be a minimum of 2 feet to a maximum of 10 feet. The conduit must be continuous without any coupling(s) or splice boxes.
  - B Rigid metal, PVC, or other flexible conduit types are not allowed.
  - C A junction box, termination or splicing enclosure is not allowed between the fused disconnect switch and the GMA.
17. Install one 90 degree, 3/4-inch diameter, UL Listed LFNC connector fitting (nonmetallic) on the end of the conduit that will be attached to the GMA. This will prevent meter panel compartment doors from being blocked.

**Note:** Do not use a straight or 45 degree connectors on the GMA end of the LFNC.



**Figure 4**  
**190 degree LFNC connector (nonmetallic)**  
**3/4-inch diameter**

18. Install one straight, 45 degree, or 90 degree UL Listed LFNC connector fitting (nonmetallic), as needed, on the end of the conduit.
19. Install three #6 AWG insulated copper wires (rated 90° C) in the LFNC. Aluminum wire or other wire sizes are not allowed.
  - A Install one hot wire with black insulation, one hot wire with red insulation, and one neutral wire with white insulation.
  - B On the GMA side, the white neutral wire should extend out 36 inches past the end of the LFNC connector to allow for proper termination inside the meter panel.
  - C On the GMA side, the black and red wires should extend out 12 inches past the end of the LFNC connector to allow for proper termination inside the GMA.
  - D PG&E will connect these wires to the GMA.

## Green Meter Adapter (GMA) for Customer Generation



**Figure 5**  
**Extend Insulated Wires Past the LFNC Conduit**

20. Connect the LFNC fitting and wires to the fused disconnect switch according to the applicable electrical codes. Refer to Figure 6 on Page 5.
21. Bond a bare copper Equipment Grounding Conductor (EGC) to the disconnect switch enclosure and connect to the electric grounding system at the meter panel. The EGC shall be sized and installed according to applicable electrical codes.
22. Install removable clamp(s) to secure the LFNC to the wall if the LFNC is more than 36" long. Do not install clamps closer than 18" from the GMA to allow for proper removal.



**Figure 6**  
**LFNC Conduit and Wires Connected in PG&E Approved Fused Disconnect Switch**

## Green Meter Adapter (GMA) for Customer Generation

23. The Point of Interconnection (POI) with PG&E is where the customer LFNC fitting, and wires enter the GMA.



**Figure 7  
Point of Interconnection**

24. Only PG&E approved GMA's are allowed for this program and installed by PG&E personnel. See Table 1 below for the GMA information.

**Table 1 PG&E Approved GMA's**

Manufacturer	Catalog/Model Number	PG&E Material Code	Generation System Size (Maximum)	Generation System(s) Backfeed or Alternative Energy Input (Maximum)
Brooks Utility	EK-4J SP5111	M241583	14.4 kW @ 240 Volts	60 amps
Marwell	1000-0-R4-SP	M241596	14.4 kW @ 240 Volts	60 amps

25. Submit pictures and a drawing showing the layout and clearances of the specified equipment for review. The layout should include the following equipment.

- 26. Electric meter panel.
- 27. PG&E gas meter, if located on same side of the house.
- 28. Fused disconnect switch.
- 29. Inverter(s).
- 30. Battery or energy Storage systems.
- 31. Conduit route from GMA to disconnect switch.
- 32. Submit the requested information in Section 3.2 for technical review.
- 33. To allow the AHJ to perform a complete and final inspection of the generation system, PG&E will install the GMA prior to the issuance of the final building permit.
- 34. Customers are required to obtain pre-approval from the local building inspection agency that the AHJ will allow the GMA to be installed and interconnected to the solar generation system. Some AHJ's may not approve this type of interconnection.

## Green Meter Adapter (GMA) for Customer Generation

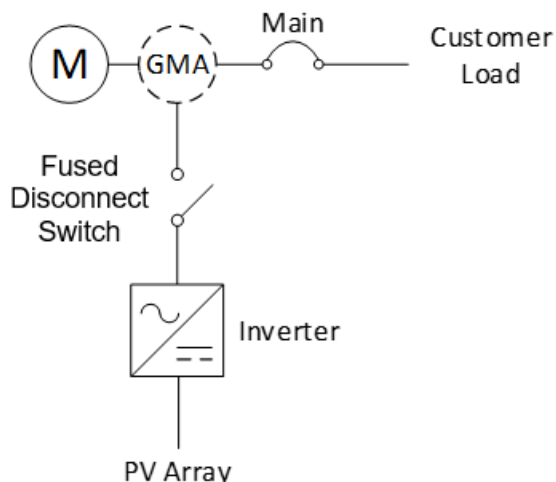


### WARNING

*The generation system must not be operated in parallel with PG&E's distribution system until the customer has received a written approval from PG&E. Before PG&E will issue a Permission To Operate (PTO) letter, proof is required that the generation system has passed the final building and electrical inspection by the AHJ.*

### Specific Interconnection Requirements

35. The customer's solar generating system, connected to the GMA, may also incorporate an energy storage system if a specific type of inverter described in 3.2 is installed or a Micro-Islanding Device (MID) is incorporated. See Figure 10 and Figure 11.
36. A PG&E approved utility interactive inverter certified by a Nationally Recognized Testing Laboratory (NRTL) with an integrated Power Control System (PCS) certified for non-import, export only, is required when an energy storage system is connected to the GMA.
37. Approved signage is affixed to the point(s) of interconnection identifying all alternative energy sources.
38. All customer generation and energy storage sources on the property that are interconnected with the PG&E service must be identified on the EGI application and submitted drawings.
39. The sum of the critical load breaker and the main breaker cannot exceed the panel ampacity rating for generation systems interconnected as shown in Figure 10 and Figure 11.
40. The Single Line Drawings (SLD) in the following figures show allowed interconnections.

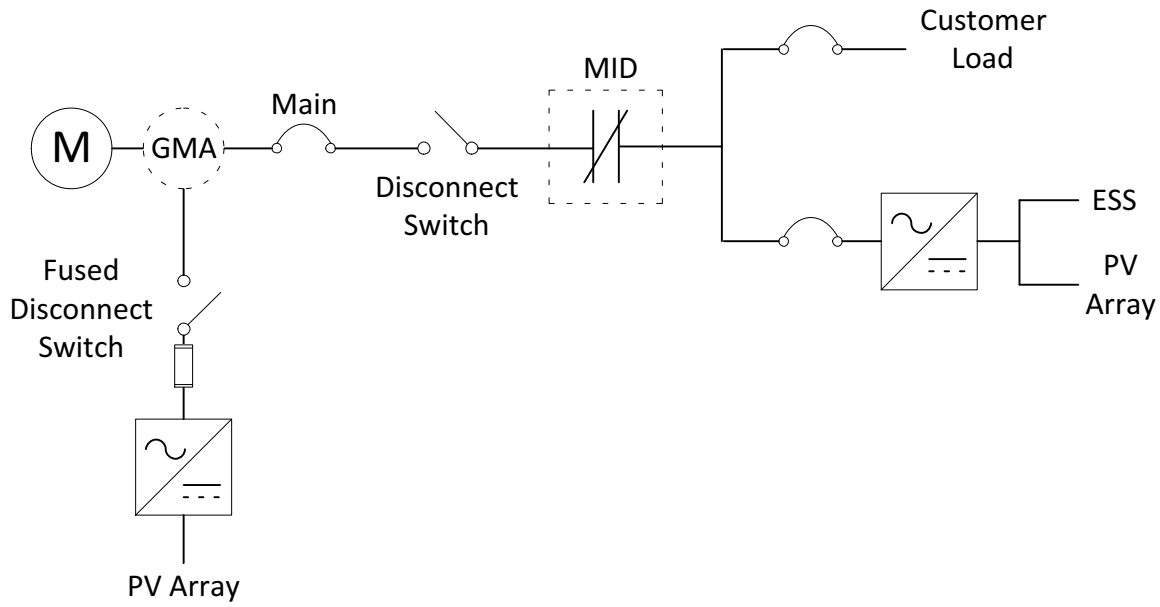


**Figure 8**  
**SLD – GMA with PV only**

#### Notes:

- Allowable with PG&E approved inverters.
- Allowable with PG&E approved disconnect

# Green Meter Adapter (GMA) for Customer Generation



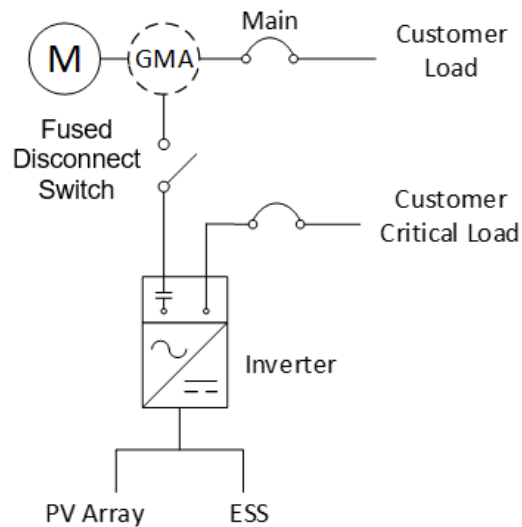
**Figure 9**  
**GMA with PV and Alternative Energy Sources**  
**Connected to the Load Side of the panel**

Notes:

- Multiple energy sources allowed
- Microgrid Islanding Device (MID) provides isolation of the backup system



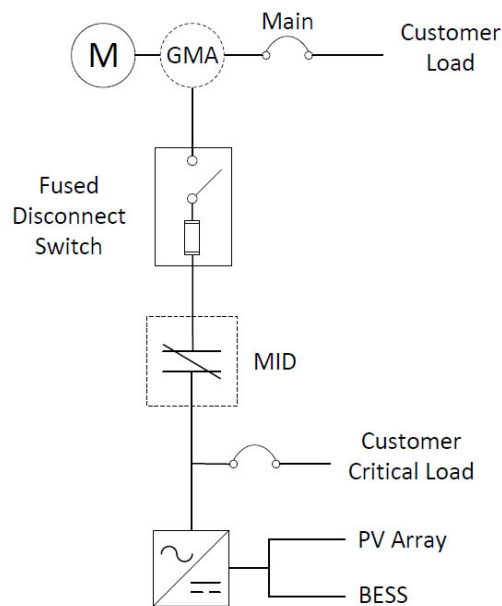
## Green Meter Adapter (GMA) for Customer Generation



**Figure 10**  
**SLD – GMA with PV, ESS, and Export Only PCS Inverter**

Notes:

- Inverter must meet UL CRD PCS for non-import – export only
- The sum of the critical load breaker and the main breaker cannot exceed the panel ampacity rating
- Inverter rating cannot exceed the GMA rating of 60 amps maximum



**Figure 11**  
**SLD – GMA with PV, ESS, and MID**

Notes:

- Grid-forming Inverter typically installed
- Microgrid Islanding Device (MID) provides isolation of the backup system from the utility
- The sum of the critical load breaker and the main breaker cannot exceed the panel ampacity rating
- Critical load breaker and ESS cannot exceed the GMA rating

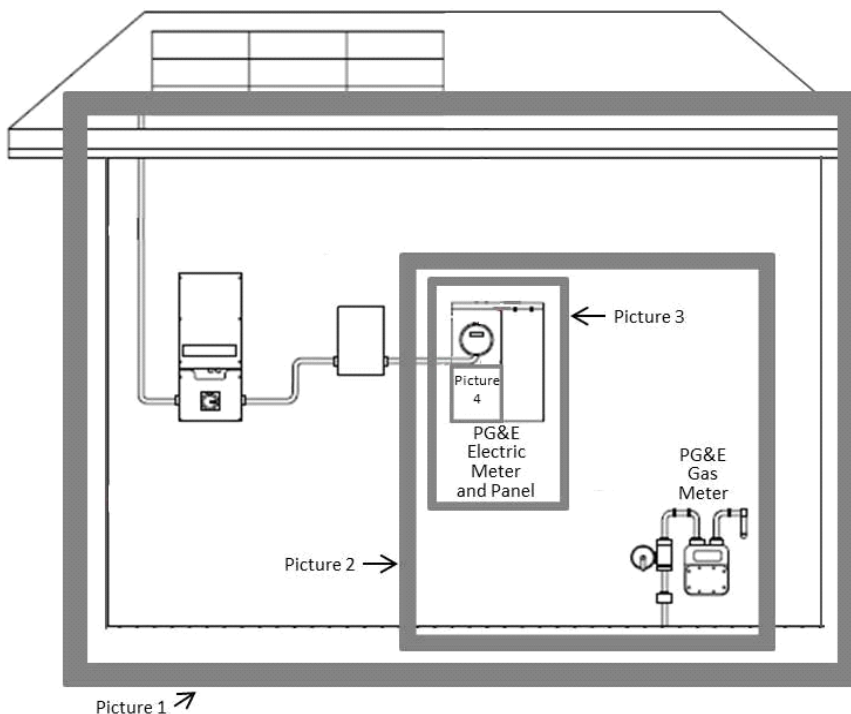
## Green Meter Adapter (GMA) for Customer Generation

---

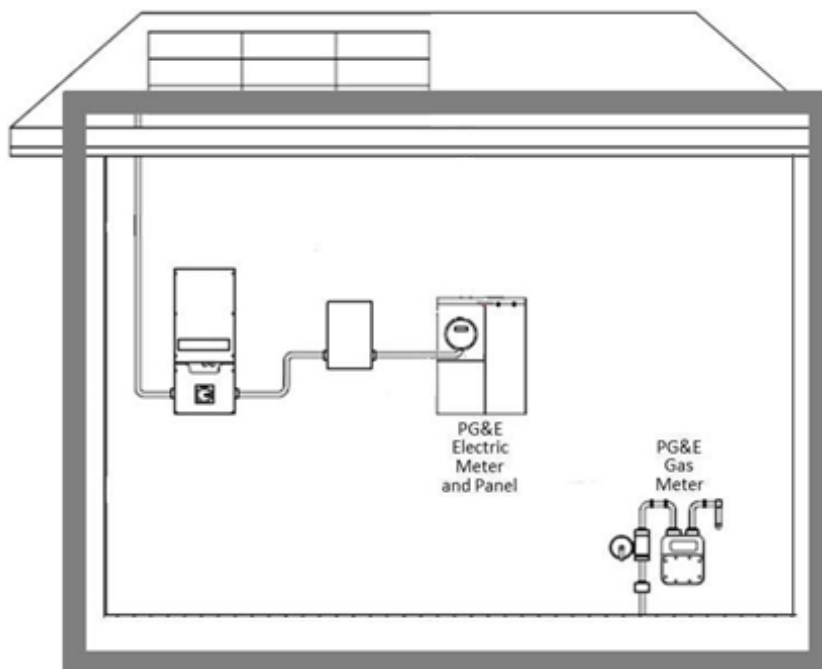
### How to Apply

41. To request a GMA, you must first complete a Standard NEM online application at [www.pge.com/standardnem](http://www.pge.com/standardnem). Then submit to PG&E's Electric Generation Interconnection (EGI) department.
42. A variance request must be selected during Step 2, on the application and noted in the Variance Request document that a Green Meter Adapter (GMA) is being requested.
43. For help with the application process, you can call the Solar Customer Service Center at [877-743-4112](tel:877-743-4112).
44. Applicants will upload the information below for the Variance Request during Step 2 of the online application process.
45. Pictures, clear and unobstructed, of the four areas described in notes 46–48 as well as shown in Figure 12 through Figure 16.  
**Note:** Do not take pictures at an angle to the wall or equipment. Pictures must be taken directly facing and perpendicular to the wall.
46. Picture Set 1: Front view of the entire wall where the gas (if applicable) and electric meters and solar equipment will be installed. This is from the top of the wall to the bottom and the whole side of the house. See Figure 13.
47. Picture Set 2: Front view, closer up, showing just the electric and gas meters. When the gas meter is on the same wall as the electric, extend a tape measure from the gas riser to the closest edge of the meter panel and include in the picture. See Figure 14.
48. Picture Set 3: Front view, close up, of the entire electric meter panel. See Figure 15. Readable close up, of all of the label for the meter panel. See Figure 16.

# Green Meter Adapter (GMA) for Customer Generation

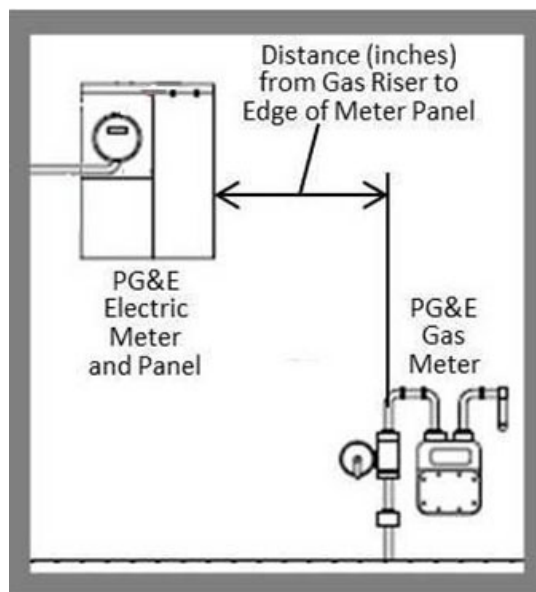


**Figure 12**  
All Picture Sets 1-3



**Figure 13**  
Side of House – Picture Set 1

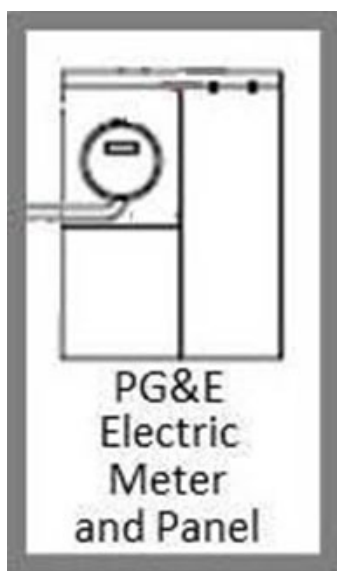
## Green Meter Adapter (GMA) for Customer Generation



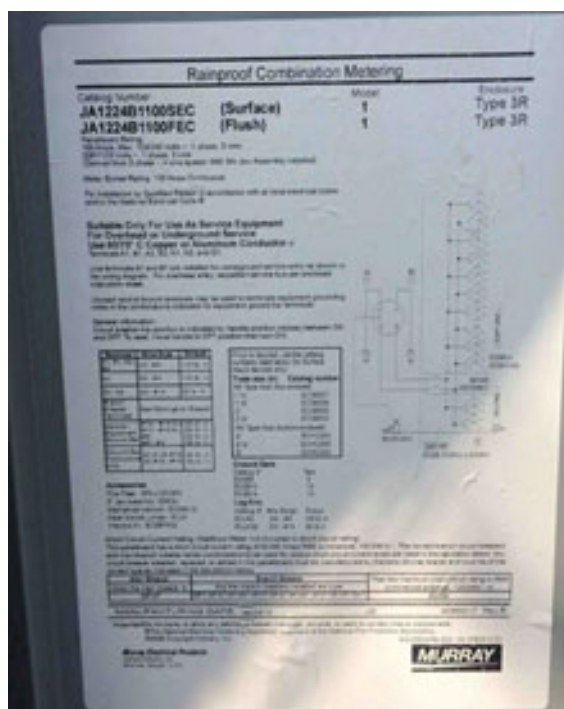
**Figure 14**  
Gas and Electric Meter Panel – Picture Set 2

Notes:

1. The 36-inch minimum clearance must be measured horizontally. A radial measurement is not acceptable.
2. A GMA will not be allowed for clearances less than 36 inches. No exceptions or variances will be given.



**Figure 15**  
Electric Meter Panel – Picture Set 3 (1)



**Figure 16**  
Electric Meter Panel Label – Picture Set 3 (2)

## Green Meter Adapter (GMA) for Customer Generation

---

49. Submit drawing(s) showing the layout of the equipment described below. The vertical heights above grade and horizontal clearances between all items must be shown on the drawing.
- A Electric meter panel.
  - B Gas meter with measured clearance from the gas riser (if located on same side of the house).
  - C Fused disconnect switch.
  - D Conduit route from the GMA to the disconnect switch.
  - E Inverter(s).
  - F Battery or energy storage systems.
  - G Grounding Electrode Conductor (GEC) and/or Equipment Grounding Conductor (EGC).
50. Material specifications for the following items must be submitted for review.
- A UL Listed Liquidtight Flexible Nonmetallic Conduit (LFNC).
  - B UL Listed Connector fittings (nonmetallic) for LFNC.
51. Pre-approval documentation and permit from the AHJ allowing the interconnection of the customer's generation system to the GMA. The following information must be included.
- A The address on the permit must match the address on the EGI application.
  - B The scope of work on the permit must include the solar installation.

Note: Some AHJ's may not allow these interconnections.

52. EGI will process the application and will request for the following.
- A A special facilities agreement signed by the customer of Record.
  - B A one-time payment for the GMA. The exact amount will be billed to the customer.
53. Note: This payment amount is for the GMA, the installation of the GMA, and any future maintenance or replacement that may be required. This amount may be subject to change.

### Additional Information

54. Other types of meter socket adapters are **not** allowed except for the GMA. Please see section 5.6.2. Installing Non-Allowed and Unauthorized Customer Equipment in PG&E's Electric & Gas Service Requirements ([Greenbook](#)).
55. Contact PG&E's Service Planning department if adding load or replacing the electric meter panel or service.

## Green Meter Adapter (GMA) for Customer Generation

## Customer GMA Checklist

Eligibility CHECKLIST	
(This is a list of the major requirements. Refer to the main document above for all of the detailed requirements and information)	
<input type="checkbox"/>	PG&E residential service customer with an electric, underground or combination meter panel.
<input type="checkbox"/>	Electric meter panel is rated for 125 amps or less and has a customer distribution section attached with a main breaker or individual breakers inside.
<input type="checkbox"/>	Solar generation connected to GMA is rated at maximum 14.0 kilowatts (kW) at 240 volts (V), with not more than 60 amps of production.
<input type="checkbox"/>	Notify PG&E and identify on all submitted drawings all sources of generation (solar, wind, energy storage, backup generation, etc.) that are on the property.
<input type="checkbox"/>	The local City, County, or State, Authority Having Jurisdiction (AHJ), has issued a permit for the installation of your generation system and pre-approved the line side connection to the GMA.
<input type="checkbox"/>	Newly installed generation equipment, including all conduits and wiring, will meet all of the PG&E gas and electric meter clearances shown in Figure 3 and in the PG&E Greenbook.
<b>Technical Requirements</b>	
<input type="checkbox"/>	A PG&E approved fused AC disconnect switch is/will be installed between 2 feet to 10 feet from the meter panel.
<input type="checkbox"/>	3/4-inch diameter, UL Listed Liquidtight Flexible Nonmetallic Conduit (LFNC) with one 90 degree and a second (straight, 45 or 90 degree) connector fitting.
<input type="checkbox"/>	<b>Three #6 AWG insulated copper wires (rated 90° C) inside and extending out of the LFNC 12" (black, red) and 36" (white).</b>
<input type="checkbox"/>	Removable clamp(s) to secure the LFNC to the wall if the LFNC is more than 36" long.
<input type="checkbox"/>	Bonded bare copper Equipment Grounding Conductor (EGC) connecting the disconnect switch enclosure and the electric grounding system with the meter panel.
<b>Specific Interconnection Requirements</b>	
<input type="checkbox"/>	A certified non-import, export inverter with an integrated PCS is installed with an energy storage system connected to the GMA.
<input type="checkbox"/>	The sum of the critical load breaker and the main breaker cannot exceed the panel ampacity rating for GMA generation systems with critical load circuits.
<input type="checkbox"/>	Affixed approved signage at the point(s) of interconnection identifying all energy sources.
<b>How to Apply</b>	
<input type="checkbox"/>	Submit a Standard NEM online application at <a href="http://www.pge.com/standardnem">www.pge.com/standardnem</a> and select "Variance Request" during Step 2 of the application process.
<input type="checkbox"/>	Upload all of the requested information (pictures, drawings, specifications, AHJ pre-approval) for review.
<input type="checkbox"/>	Sign and submit the special facilities agreement and one-time payment when requested by EGI.
<input type="checkbox"/>	For help call the Solar Customer Service Center at 877-743-4112.

## Green Meter Adapter (GMA) for Customer Generation

---

### Revision Notes

Revision 00 has the following changes:

1. Converted Bulletin TD-7001B-007 to this new numbered engineering document.
2. Made minor updates throughout document.