	AGRICULTURAL UNDERGROUND SERVICE 500 HP OR LESS		054619
	Asset Type: Electric Metering	Function: Design and Construction	
Issued by: Lisseth Villareal (LDV2)		Date: 07-31-15	
Rev. #10: This document replaces PG&E Document 054619, Rev. #09. For a description of the changes, see Page 7.			

This document is also included in the following manual:

- [Electric and Gas Service Requirements \(Greenbook\)](#)
- [Electric Meter Work Practices](#)

Purpose and Scope

This document establishes and illustrates the preferred methods of providing underground agricultural service of 500 hp or less.

The requirements shown on this document shall apply to agricultural underground service installations, from PG&E's overhead lines, for connected loads of 500 hp or less. This document applies where there is a suitable service post, building, or structure as approved by PG&E for attaching the service conduit and metering equipment. For requirements applicable to agricultural service poles (overhead service only) refer to PG&E's [Document 058087](#). The customer should contact the local PG&E office for installations larger than 500 hp or other underground installations from underground systems as these installations may require different facilities.

General Information

1. PG&E shall furnish and install transformers, service conductors (in accordance with [PG&E's Electric Rule 16](#)), meters, and metering current transformers. Unless otherwise stated, all other materials shall be furnished, installed, and maintained by the customer and shall comply with the requirements of PG&E. It shall be the responsibility of the customer to ascertain and comply with the requirements of governmental authorities having jurisdiction. In areas where no provision is made for inspection by local authorities, the applicable state regulations shall apply. Local ordinances may include wiring requirements in addition to those shown in this document or in the National Electrical Code. Consult inspection authorities for requirements, city or county permits, and inspections which may be required before service can be connected.
2. The customer should apply for service and verify the available service voltage with PG&E as far in advance of construction as possible. The customer should then notify his pump company of the available PG&E voltage.
3. Available Service Voltage: Non-residential single-phase loads to a maximum of 7-1/2 hp shall be served at 120/240 V, single-phase, 3-wire. Three-phase motors of 5 hp, but less than 30 hp, will normally be served at 120/240 V, three-phase, 4-wire, but may be served at 120/208 V or 277/480 V at the customer's option and if capacity is available from existing facilities. Single or grouped three-phase motors of 30 hp to 50 hp can be served at 120/240 V, three-phase, 4-wire, if the customer has a combination of single and three-phase loads, otherwise they must be served at 120/208 V or 277/480 V, three-phase, 4-wire. Single or grouped three-phase motors from 60 hp to 125 hp shall be served at 120/208 V or 277/480 V, three-phase, 4-wire. Three-phase motors larger than 125 hp shall be served at 277/480 V, 4-wire.
4. If one or more service posts are used to support the service conduit and metering equipment, or a panel board on which the service and metering equipment are mounted, they shall meet the minimum requirements outlined in [Document 054712](#) for service posts and [Document 065374](#) for panel board construction. Service posts can be installed for applications from 0 to 200 amps, otherwise, panel board construction is needed.

5. Service Conduit and Termination

- A. Service termination shall be in a PG&E-approved service termination facility. Refer to Figure 5 on Page 6 through Figure 8 on Page 7 for typical installations.
 - B. In accordance with [PG&E's Electric Rule 16](#), PG&E shall install the service riser and conduit sweep at PG&E's pole, and shall pull and connect the service lateral to the customer's termination facilities. The customer shall provide and install all conduits and other substructures as necessary and shall trench from the base of PG&E's pole or customer's property line to the service termination point.
 - C. The minimum conduit size is based on the maximum continuous ampacity of the metering equipment. Refer to [Document 063928](#) to select the appropriate size and number of conduits.
 - D. Underground conduit (Item 5) is restricted to the following types:
 - (1) Hot-dip galvanized rigid steel.
 - (2) PVC, Schedule 40 or 80, UL approved 90°C.
 - (3) PVC marked ASTM F-512, DB120 or better, with prior local PG&E approval. Riser conduit (Item 7) is restricted to galvanized rigid steel.
 - E. When the conduit enters an enclosure for service termination, end bells should be installed, unless the conduit has been installed in an enclosure equipped with duct terminators. Cable protectors should be installed on reconstruction projects only, when end bells cannot be installed. Refer to [Document 062288](#) for more information about conduit fittings.
 - F. The minimum depth of the customer's underground conduit shall be 24 inches for secondary or 30 inches for primary. If the underground service is in a location subject to erosion, sub-soiling, or ripping, conduit should be buried at a depth sufficient to avoid possible damage, but not less than 24 inches.
 - G. PG&E will determine the point-of-service termination to avoid unsuitable routing of underground service installations.
6. If a pad-mounted transformer is used, the customer shall provide the transformer concrete pad. Dimensional details and additional trenching requirements will be provided by the local PG&E office.
7. The customer shall be responsible for bonding and grounding all exposed non-current carrying metal parts. Grounding shall be in accordance with National Electric Code, local ordinances, and PG&E requirements. Do not install a bonding jumper or ground wire inside of any PG&E sealed section. Bonding jumper or ground wire attachments to the outside of the meter cabinet are allowed.

8. Metering Requirements

- A. The meter sequence shall be meter-switch-fuse for all installations.
- B. The customer shall provide and install a self-contained meter socket or current-transformer metering enclosure, approved by PG&E, for the available service voltage, in accordance with Table 1 on Page 4 and the illustrations on Page 5.
- C. For agricultural services, the rating of the service supplied will be determined by the ampacity rating of the metering equipment or enclosure (typically, whichever is greater) where the service conductors terminate.

9. Customer's Control Equipment

- A. Customer's switch and motor control equipment may be installed on the same post or panel board as the underground service terminating and metering equipment.
- B. Customer's switch and motor control equipment shall be of proper horsepower and voltage rating and shall be weatherproof. This equipment shall include three overcurrent units, one in each phase, for protection of each three-phase motor or as otherwise specified in Article 430 of the National Electric Code.
- C. Customer's switch and motor control cover shall be effectively locked or sealed if the enclosure contains accessible electrically energized parts.

10. Service to Three-Phase Pumps

- A. When three-phase service is established to a pump, PG&E's crew will assist in checking for satisfactory pump motor performance if the customer or his representative is present. The construction crew should take "clamp-on" ammeter readings at the service head, or the customer or his representative can take the readings at the motor control box. If the reading on the "high" phase is more than 10% higher than the reading on the "low" phase, then the phases should be rolled to get the readings as close as possible (see Figure 1 below). The set of readings that gives the lowest difference is the connection to be retained. It is possible that none of the other readings will be any better. Record all readings.
- B. Starting and stopping of the pump should be done only by the customer or his representative. Connections can be changed at the transformer pole or service pole by PG&E's crew or at the motor control box by the customer or his representative.
- C. On 240 V 3-wire services where one phase conductor is grounded, all rolling of leads must be done on the customer's motor leads (at the motor control box), **not** on PG&E's service leads.

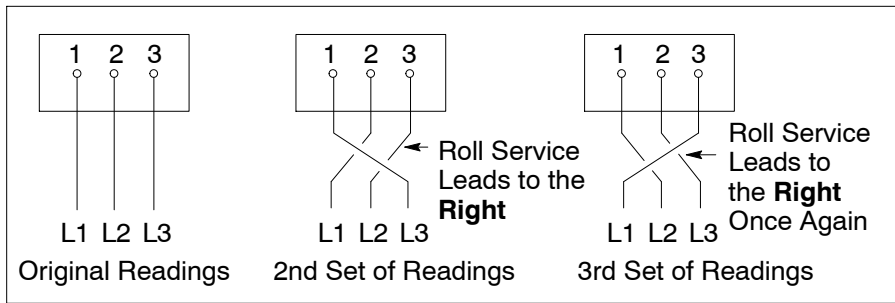

Figure 1
Rolling Leads
(maintains same rotation)

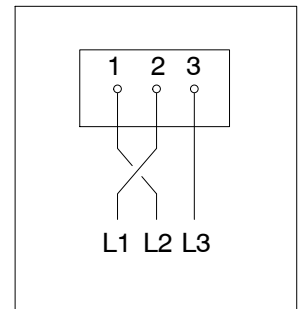

Figure 2
Interchanging Leads
Reverses Rotation
(for information only)

Example: Once water was flowing satisfactorily from the pump, the following ammeter readings were taken:

	<u>Amps</u>		
	<u>L1</u>	<u>L2</u>	<u>L3</u>
A. Original Readings	60	61	67
B. Second Set of Readings	60	62	63
C. Third Set of Readings	59	62	66

Conclusion: Connection "B" should be used.

11. A voltage stabilizer shall be installed in all 480 V three-phase, 3-wire ungrounded service. See [Document 052497](#).

References	Location	Document
Installation of Meter Protective Device on 480 V Services	ELS	033286
Voltage Stabilizer for 480 Volt Three-Phase, 3-Wire, Ungrounded Service	OH: Meters/EMWP	052497
Permanent Wood Post Installation Underground Electric Service	UG-1: Services/Greenbook	054712
Agricultural Overhead Service 300 HP or Less	OH: Services/Greenbook	058087
Underground Conduits	UG-1: Conduits	062288
Methods and Requirements for Installing Commercial Underground Electric Services 0-600 Volts to Customer-Owned Facilities	UG-1: Services/Greenbook	063928
Overhead and Underground Panel Board Construction	OH/UG-1: Services/Greenbook	065374

Typical Underground Service

Table 1 Customer's Metering Equipment Requirements ¹

Service Voltage ²	Maximum Horsepower ³ Single or Grouped Motors	Metering Equipment's Current Rating (maximum amps shown) ⁶	Type Meter Equipment Required	Refer to
120/240 Volt Single-Phase, Non-Residential, 3-Wire	7 1/2 hp Single	100	Self-Contained, 4-Jaw Bused Safety-Socket Meter Box	Figure 5, Page 6
240 Volt Delta 3-Phase, 3-Wire ⁴	30 hp Single or Grouped	100	Self-Contained, 5-Jaw Bused Safety-Socket Meter Box	Figure 6, Page 6
	60 hp Single or Grouped	200		
240/120 Volt Delta 3-Phase, 4-Wire	30 hp Single or Grouped	100	Self-Contained 7-Jaw Bused Safety-Socket Meter Box	Figure 7, Page 6
	50 hp Single or Grouped	200		
480 Volt Delta 3-Phase, 3-Wire ⁵	60 hp Single or Grouped	100	Self-Contained 5-Jaw Bused Safety-Socket Meter Box	Figure 6, Page 6
	125 hp Single or Grouped	200		
	300 hp Single or Grouped	400	Combination Meter, Current- Transformer, and Service Termination Cabinet with 8-Jaw Socket and CT Mounting Base	Figure 8, Page 7
277/480 Volt Wye 3-Phase, 4-Wire	60 hp Single or Grouped	100	Self-Contained 7-Jaw Bused Safety-Socket Meter Box	Figure 7, Page 6
	125 hp Single or Grouped	200		
	300 hp Single or Grouped	400	Combination Meter, Current-Transformer and Service Termination Cabinet with 13-Jaw Socket and CT Mounting Base	Figure 8, Page 7
	500 hp Single or Grouped	600	Pad-Mounted (free standing) Switchboard	Greenbook Section 10

¹ For meter equipment illustration, see Pages 6 and 7.

² See Note 3 on Page 1 for available service voltages.

³ Maximum horsepower for single and grouped motors is based on nameplate ratings. Ratings shown are the recommended values for motors running at full load.

⁴ Limited availability, consult PG&E.

⁵ 480 Volt Delta is not available to new services.

⁶ Customers may choose a greater current rating for their metering equipment.

Typical Underground Service (continued)

Note

1. Voltage stabilizer shall be furnished and installed by PG&E. Refer to [Document 052497](#).

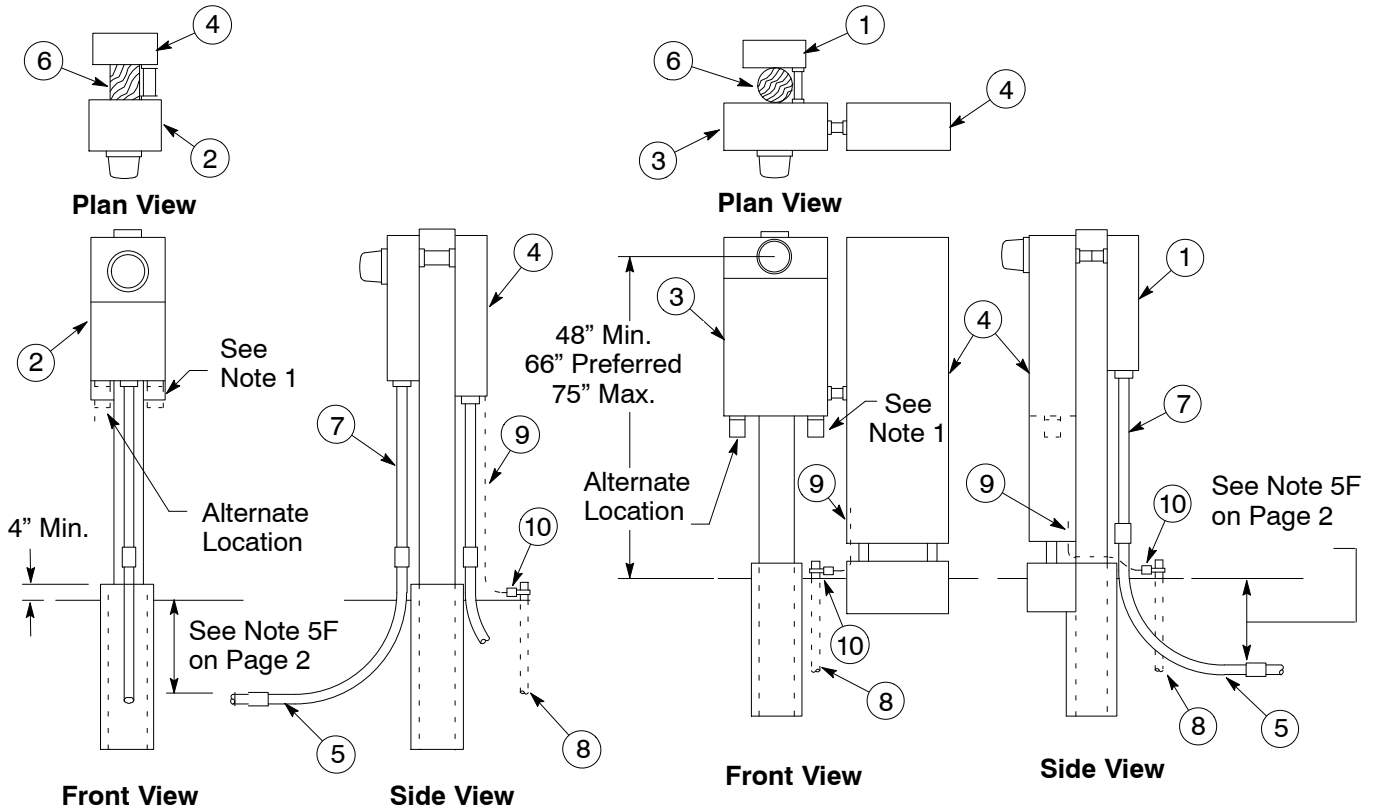

**Figure 3
Safety Socket Box and
Service Equipment
Enclosure**

**Figure 4
Meter and CT Cabinet
With Free-Standing
Pad-Mounted Service
Equipment Enclosure**

Table 2 List of Materials to Be Furnished and Installed by the Customer

Item	Description
1	Underground Pull Box (see Figure 8 on Page 7)
2	Self-Contained Bused Safety Socket Box (see Figure 5, Figure 6, and Figure 7 on Page 6)
3	Combination Meter and Current-Transformer Cabinet
4	Main Switch or Service Equipment Enclosure
5	Service Conduit (see Note 5D on Page 2)
6	Post (see Note 4 on Page 1)
7	Conduit, Riser, Galvanized (see Note 5D on Page 2)
8	Ground Rod (see Note 7 on Page 2)
9	Ground Wire, Copper, Bare, or Armor Clad (see Note 7 on Page 2)
10	Ground Clamp, as Required, for Item 9

Safety Socket Meter Boxes

Notes

1. Applicable to maximum of 125 hp motor(s) (self-contained).
2. Refer to PG&E's [Electric and Gas Service Requirements \(Greenbook\)](#) for dimensional and specification details.
3. A voltage stabilizer, required on 480 V ungrounded services, shall be furnished and installed by PG&E. See [Document 052497](#).
4. 240 V, three-phase, 3-wire service is available only when PG&E's transformers are of the overhead type, the load is limited to three-phase motors (small 240 V, single-phase loads may be permissible in some locations), and in the future other customers are not likely to be served from the transformer bank.

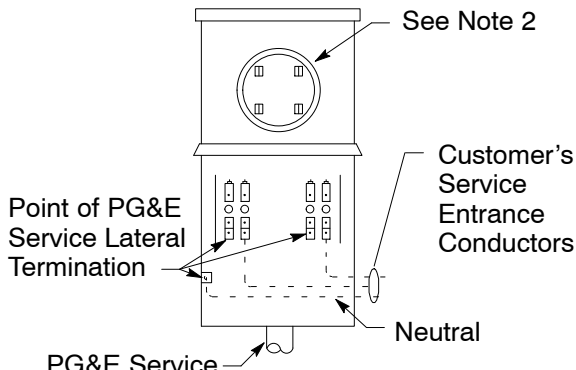

Figure 5
0 – 200 Amp Safety Socket Meter Box
120/240 V, Single-Phase, Self-Contained
4-Jaw Bused

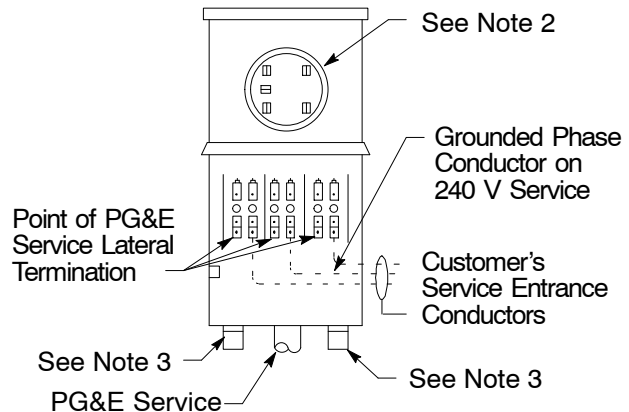

Figure 6
0 – 200 Amp Safety Socket Meter Box
240 V and 480 V, Three-Phase, 3-Wire, Self-Contained
5-Jaw Bused (see Notes 1 and 2)

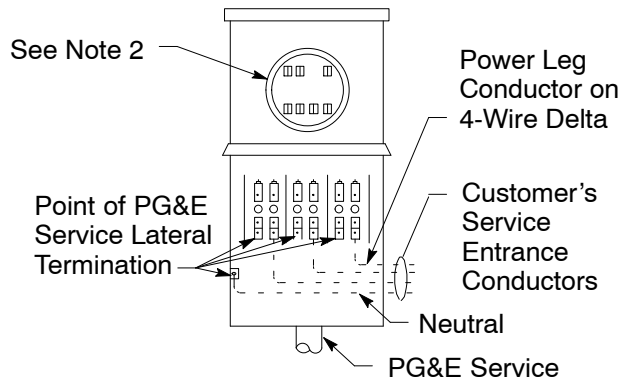

Figure 7
0 – 200 Amp, Safety Socket Meter Box
240/120 V, Three-Phase, 4-Wire Delta
or 480/277 V, Three-Phase, 4-Wire, Wye Self-Contained
7-Jaw Bused (see Note 1)

Transformer-Rated Enclosures and Metering

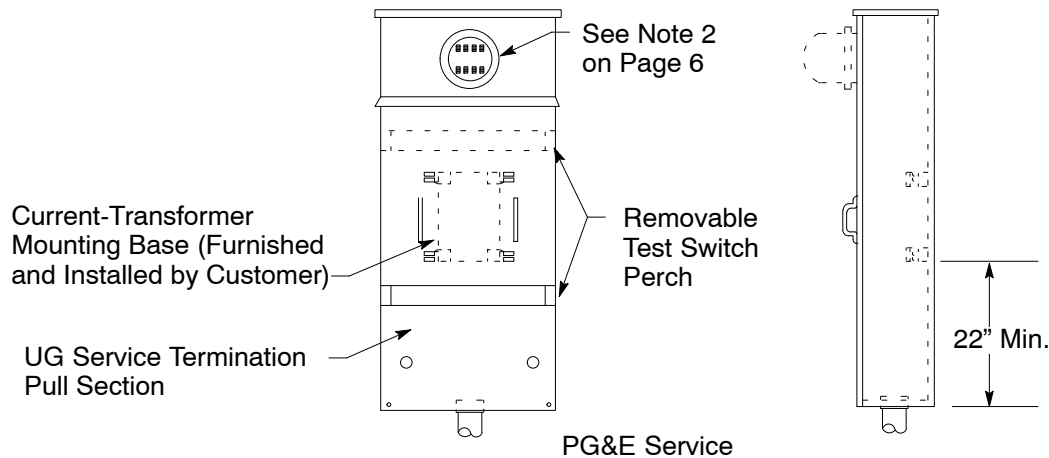

Figure 8
400-Amp Service Terminating Pull Box and Combination Meter and Current-Transformer Cabinet
240 V, Three-Phase, 3-Wire or 480 V, Three-Phase, 3-Wire Delta
240/120 V, 3-Phase, 4-Wire Delta or 480/277 V, Three-Phase, 4-Wire Wye
Three-Phase, 3-Wire Service Equipment is Shown (see Note 4 on Page 6)

Notes

1. Applicable to maximum of 300 hp motor(s).
2. Refer to PG&E's [Electric and Gas Service Requirements \(Greenbook\)](#) for dimensional and specification details.
3. A voltage stabilizer, required on 480 V ungrounded services, shall be furnished and installed by PG&E. See [Document 052497](#).
4. 240 V, three-phase, 3-wire service is available only when PG&E's transformers are of the overhead type, the load is limited to three-phase motors (small 240 V, single-phase loads may be permissible in some locations), and in the future other customers are not likely to be served from the transformer bank.
5. Figure 8 is applicable to wall-mounted, termination enclosures with a maximum rating of 400 amps. Larger termination equipment (600 amps, three-phase) must be pad-mounted.

Revision Notes

Revision 10 has the following changes:

1. Corrected available service voltage for three-phase motors of 5 hp but less than 30 hp shown on Note 3 on Page 1.
2. Clarified 3rd column of Table 1 on Page 4.
3. Revised Table 1 Footnotes 3 and 6 on Page 4.