

PACIFIC GAS AND ELECTRIC COMPANY

ZERO NET ENERGY PRODUCTION
BUILDER DEMONSTRATION

ZERO NET ENERGY BUILDER RESOURCE GUIDE



Pacific Gas and Electric Company

ZERO NET ENERGY BUILDER RESOURCE GUIDE

PROJECT MANAGER

Peter Turnbull, Pacific Gas and Electric Company

PREPARED BY

Ann Edminster, Design AVEnues LLC

Rick Chitwood, Chitwood Energy Management

ISSUED

August 2018

© Copyright 2018, Pacific Gas and Electric Company. All rights reserved.

ACKNOWLEDGEMENTS

This *Guide* was developed as part of Pacific Gas and Electric Company's Zero Net Energy Production Builder Demonstration. It was written by Ann Edminster (Design AVEnues LLC) with Rick Chitwood (Chitwood Energy Management). Peter Turnbull, Conrad Asper, and Can Anbarlilar (PG&E), as well as Anna LaRue and Margaret Pigman (Resource Refocus LLC), provided general oversight. Terry Nordbye and Bruce King both provided valuable commentary on draft materials, and many other individuals contributed key bits of information. Gas Technology Institute generously permitted us to include several of Bruce King's drawings in Section 3 that were developed as part of CEC project EPC-16-001, Measured Results from Affordable Zero Net Energy Homes.

Photos by Rick Chitwood except as noted otherwise.

Design by Debra Turner, Illustrations by Steven Lee.

ONLINE VERSION

The PDF version of this document, which will be made available at pge.com/zne as a free download, contains live links to the online resources that are referenced.

LEGAL NOTICE

This report was prepared for Pacific Gas and Electric Company for use by its employees and agents. Neither Pacific Gas and Electric Company nor any of its employees and agents:

- (1) makes any written or oral warranty, expressed or implied, including, but not limited to those concerning merchantability or fitness for a particular purpose;
- (2) assumes any legal liability or responsibility for the accuracy, completeness, or usefulness of any information, apparatus, product, process, method, or policy contained herein; or
- (3) represents that its use would not infringe any privately owned rights, including, but not limited to, patents, trademarks, or copyrights.

This *Guide* is intended to provide critical information that will be needed at key stages in the development of the ZNE homes.

COVER PHOTOS

(clockwise from top left)

The Cottages at Cypress, Fort Bragg, CA
K. Boodjeh Architects, Danco Group, 2014
Brandi Easter photo

The Cottle House, San Jose, CA
One Sky Homes, 2012

Walhalla, Sierra Crest, Fontana, CA
BSB Design, Meritage Homes, 2017
Applied Photography & Graphic Services

ZETA Townhouse, Oakland, CA
ZETA Communities
dsa architects, 2009

TABLE OF CONTENTS

SECTION 1. INTRODUCTION	6	Figure 3-1 24-inch-on-center framing with opening aligned with stud spacing	21
About the Guide	6	Figure 3-2 Single top plate	21
Background	7	Figure 3-3 Drywall clips	21
About Context	7	Figure 3-4 Engineered header with raised-heel truss	22
General Resources	8	Figure 3-5 Raised heel trusses	22
 		Figure Figure 3-6 Attic access in garage – not penetrating ceiling insulation	23
SECTION 2. GETTING TO ZNE SUCCESSFULLY	9	Figure 3-7 Engineered single top plate, from above.....	23
The Toolbox: Factors that Influence ZNE Achievement.....	9	Figure 3-8 Engineered headers.....	23
Table 2-1 ZNE Performance Factors.....	10	Figure 3-9 Advanced framing wall plan and elevation	24
Lessons Learned (Pitfalls to Avoid)	11	Other Resource Efficiency Measures.....	25
Implementation Timeline	13	Figure 3-10 Ground-constructed gable-end truss assembly being craned into place	25
Figure 2-1 Cost & effort of design changes as project progresses.....	13	Figure 3-11 Drywall splicing	24
Table 2-2. Critical points in ZNE timeline.....	14	Figure 3-12 Studs pre-drilled for wiring	25
Getting to ZNE Resources	16	Airtightness and Air Sealing	26
 		Figure 3-13 Detail 3 and air sealing key from continuous air barrier drawing.....	27
SECTION 3. ENVELOPE	17	Figure 3-14 Continuous air barrier drawing	27
Envelope ZNE Strategies	17	Cavity Insulation	28
Form Factors	17	Continuous Exterior Insulation	28
Envelope Specifications	18	Windows and Shading	29
Table 3-1 Sample ZNE envelope specifications.....	18	Enclosure Resources	30
Roof/Attic	19		
Walls – Advanced Framing	20		

SECTION 4. HEATING, VENTILATION, & AIR CONDITIONING...	33
Successful Heating, Ventilation, and Air Conditioning for ZNE Homes	33
HVAC Specifications	34
'Just-Right' HVAC System Design	33
Table 4-1. <i>Sample HVAC specifications</i>	34
Table 4-2. <i>Sample cooling equipment sizing for California ZNE homes</i>	35
The "V" in HVAC Stands for Ventilation	36
HVAC Installation Quality	36
Engaging Installers in Commissioning	37
Table 4-3. <i>Sample mechanical and enclosure commissioning report, Stockton, CA</i>	38
HVAC Resources	39
 SECTION 5. WATER HEATING	 40
Water Heating Design Factors	40
Water Heating System Specifications	41
Table 5-1 <i>Sample water heating system specifications</i>	41
Hot Water Distribution	41
Figure 5-1 <i>Compact hot water layout</i>	42
Figure 5-2 <i>Water distribution manifold and installation schematic</i>	42
Quality Installation	44
Water Heating Resources	44

SECTION 6. ELECTRIC LOADS & PRODUCTION	45
Electric Loads	45
Electric Specifications	45
Table 6-1 <i>Sample electric load-related specifications</i>	45
Renewable Electricity Production	46
Table 6-2 <i>ZNE homes with PV system sizes</i>	46
Electric Load Resources	47
Glossary	48
Acronyms	49



Brideveil, Sierra Crest, Fontana, CA
 BSB Design, Meritage Homes, 2017
 Applied Photography & Graphic Services

SECTION 1. INTRODUCTION

ABOUT THE GUIDE

This *Zero Net Energy Builders' Resource Guide* was developed as a reference for builders interested in advancing their homes towards zero net energy (ZNE) performance, as an outgrowth of PG&E's prior demonstration efforts with production builders.

The *Resource Guide* focuses on aspects of design and construction that are likely to differ from standard, non-ZNE projects. It is intended to provide critical information that will be needed at key stages in the development of the ZNE homes. Those stages, and the relevant information at each stage, are identified in Section 2, Table 2-2; use this to guide your work between the milestones described above.

This *Resource Guide* is a concise summary of key actions and guidance to assist in achieving a smooth transition to ZNE performance; it is also, as the title implies, a reference to additional helpful resources – in most cases, with much more detail – that are readily available elsewhere. It is not a standalone resource that contains everything you need to know to design and build ZNE homes.

In combination, these resources are intended to provide a reasonably thorough set of guiding information for those who wish to create ZNE homes. A list of relevant resources is included at the end of each section. Some of the listed resources are free, others available at relatively modest prices.



El Capitan, Sierra Crest, Fontana, CA
BSB Design, Meritage Homes, 2017
Applied Photography & Graphic Services

This *Guide* is a concise summary of key actions and guidance to assist in achieving a smooth transition to ZNE performance.

BACKGROUND

PG&E has engaged in numerous ZNE activities in response to California's by now widely-known goal of having new residential construction achieve ZNE by 2020. In the forthcoming Title 24-2019 and subsequent code cycles, the energy code will continue to advance towards ZNE, and PG&E remains committed to supporting the builder community in meeting the State's energy goals.

Earlier phases of the ZNE Production Builder Demonstration provided many insights about strategies that made ZNE achievable at lowest cost – or even at savings – compared with standard construction. (A full description of one project is provided in *Final Report*, March 2017, PG&E Zero Net Energy Production Builder Demonstration, Habitat for Humanity of San Joaquin County Dream Creek Subdivision, Stockton, CA – available for download at <https://www.etcc-ca.com/reports/zero-net-energy-production-builder-demonstration>.)

We also learned about some pitfalls demonstration builders experienced in achieving ZNE. This Resource Guide is a road map to achieving ZNE successfully and affordably – by bypassing those very pitfalls. Of course, change of any kind always presents some challenges, but our goal is to make the experience of building ZNE homes as smooth as possible.

ABOUT CONTEXT

We recognize that home design and construction are always specific to their context – the local climate, labor force, seismic zone, policies and ordinances, the builder's company culture, and buyer values. These factors all influence the final product. The counsel in this *Resource Guide* is intended to be adapted as appropriate to each builder's unique context. In particular, note that the guide was written for builders in our typically dry California climates, and as such, certain recommendations may not be appropriate in other places.

**PG&E is committed to supporting
the builder community in meeting
the State's energy goals.**



GENERAL RESOURCES

The PDF version of this document, which will be made available at pge.com/zne, includes live links to the online resources listed below.

In addition to topic-specific resources provided in subsequent sections, several general resources, some of which are referred to repeatedly throughout this guide, are listed below. Before starting to design a new ZNE home, we encourage you to acquire these so that they are at hand as you delve into this *Resource Guide*. They are listed **in bold** by 'shorthand' names as well as by their formal titles.

ZNE Primer – *ZNE Primer*, Ann Edminster, American Institute of Architects - California Council, 2018, <https://energycodeace.adobeconnect.com/aia-zne-guide/> (free download)

PG&E Stockton – *Final Report*, March 2017, Pacific Gas and Electric Company Zero Net Energy Production Builder Demonstration, Habitat for Humanity of San Joaquin County Dream Creek Subdivision, Stockton, CA, <https://www.etcc-ca.com/reports/zero-net-energy-production-builder-demonstration> (free download)

Light Wood Framing – *Light Wood Framing for Efficiency and Economy*, Bruce King, Ecological Building Network, <http://www.ecobuildnetwork.org/images/pdfs/Framing-Efficient-King.pdf> (free download)

Builder's Guide – *Builder's Guide to Hot-Dry & Mixed-Dry Climates* (print), Joseph Lstiburek, Energy & Environmental Building Association, 2004; or *Builder's Guide to Mixed-Humid Climates* (download), Joseph Lstiburek, Building Science Corporation, 20091, <https://buildingscience.com/bookstore>

Energy Free – *Energy Free: Homes for a Small Planet* – a guide to designing and building zero-energy homes. Ann Edminster, Green Building Press 2009, <http://www.greenbuildingpress.com/energy-free>

Before starting to design a new ZNE home, we encourage you to acquire these additional resources to have on hand as you delve into this *Guide*.

¹ To determine which *Builder's Guide* is applicable to your location, consult a *non-California* climate zone map, e.g., Energy Vanguard, Do You Know Your Building Science Climate Zone?, <http://www.energyvanguard.com/blog/59387/Do-You-Know-Your-Building-Science-Climate-Zone>.

SECTION 2. GETTING TO ZNE SUCCESSFULLY

THE TOOLBOX: FACTORS THAT INFLUENCE ZNE ACHIEVEMENT

At the most basic level, achieving ZNE is about two things:

1. **Reducing demand by improving energy efficiency, cost-effectively.** The universal elements of ZNE homes are a very well-sealed, well-insulated, envelope; efficient space conditioning and water heating systems; and highly efficient electric loads – lighting and appliances.
2. **Supplying the remaining demand with renewable energy.** In California, this typically means installing a rooftop photovoltaic (PV) solar electric system.

In this section we discuss this general approach, with additional information on specific systems provided in the remaining sections:

- Section 3 – Envelope
- Section 4 – Heating, Ventilating, and Air conditioning
- Section 5 – Water Heating
- Section 6 – Electric Loads and Production
- Appendix – Glossary, Acronyms

The roof is critical for making the ZNE equation work – the available roof space must be large enough, and face the right direction (generally, south or southwest, here in the northern hemisphere) to fit the needed amount of PVs. Simple ... in principle.

In practice, this means optimizing the energy performance of the various factors that influence efficiency and roof area, while also balancing cost and other variables (e.g., façade design, product availability, and trade capabilities), to come up with the most cost-effective package of measures.

The more efficient the home, the less space you will need for PVs and the more flexibility you will have with roof design. Conversely, a less efficient home will need more PV panels and thus will dictate a simpler roof form. It's a tradeoff – or in reality, a bunch of tradeoffs.

You, as the builder, are in the best position to evaluate these tradeoffs; to assist you in doing so, we have provided a comprehensive list of the relevant factors in Table 2-1. Sections 3 through 6 provide more information about these factors, including relevant details, specifications, and references to additional resources.

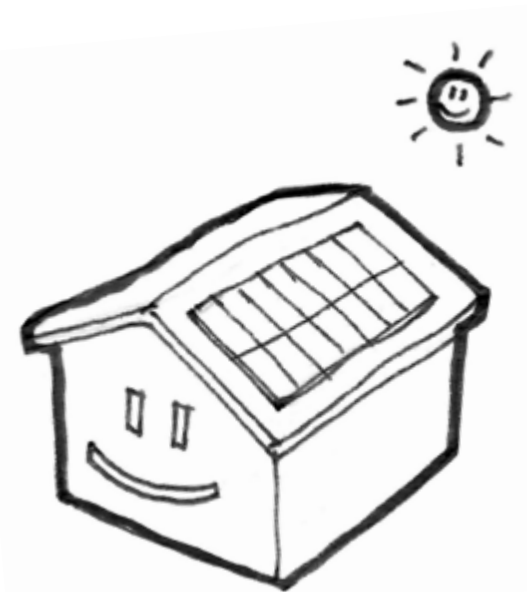

Table 2-1. ZNE performance factors

Overarching

- fuel selection
- house orientation
- house geometry
- roof geometry

Insulation & Air Sealing

- insulation quantity & quality, walls
- insulation quantity & quality, attic/roof
- insulation quantity & quality, floors/foundation
- "cool" roof
- airtightness/air sealing
- roof radiant barrier

Windows & Glass Doors

- orientation (% each N-S-E-W)
- size (area)
- type of operation/airtightness
- condition/age
- glazing (U, SHGC)
- frame material
- overhangs & other shading strategies

Water Heating

- water heater efficiency
- hot water distribution
- pipe insulation
- drain water heat recovery
- solar pre-heat

Heating

- installation quality
- equipment efficiency
- proper sizing
- location

Cooling

- installation quality
- equipment efficiency
- proper sizing
- ceiling fans
- ventilation cooling/night flushing
- thermal mass

Ducts

- installation quality/leakage rate
- location & layout
- return air path
- duct insulation

Electrical Load

- lighting technology (LED, CFL)
- lighting controls
- appliance efficiency
- condition/age

Pool/Water Features

- size
- cover type (insulating/not)
- pump type

LESSONS LEARNED (PITFALLS TO AVOID)

We often hear concerns from builders, before trying ZNE, that achieving ZNE will cost too much or will require unproven and risky techniques or equipment. This *Resource Guide* is specifically developed based on strategies that are highly cost-effective and do not require the use of unproven, risky approaches. However, there are challenges, and pitfalls to be avoided.

The vast majority of challenges we have seen builders grapple with in their early ZNE projects fall into three broad categories:

- Pre-existing designs;
- Gaps in the contract documents; and/or
- Tendency to default to standard practices.

Each of these issues is discussed below.

Pre-existing Designs

Developing home designs is a serious investment. Changing those designs is likewise an investment, and often requires buy-in from management and other decision-makers. It is a business decision. The goal of achieving ZNE is also a business decision; choosing to pursue ZNE *without* a commitment by all decision-makers to examine, and possibly change, a home design represents a major obstacle – and a cost.

Here's why: If a home design cannot be adapted to accommodate a ZNE goal, then the way that goal is achieved is unavoidably additive: add more PVs, add more expensive equipment, add pricier windows. This additive approach avoids investing in design changes (and spreading out those costs over all successive homes built using the new designs), while instead requiring investing in expensive additions to the price tag of each individual home.

For California builders, learning to build ZNE homes soon will be necessary to comply with the State's evolving energy code. The additive approach is a short-term investment – and one without a real return, whereas incorporating design changes

aimed at achieving ZNE is a long-term investment in building a next-generation, high-performance product line – economically, risk-free, and ahead of deadlines.

Thrive Home Builders in Metro Denver initially tested the waters with ZNE by offering it as an upgrade to their standard models – the additive approach. When they later committed to designing ZNE homes from the ground up, they found were able to build the designed-to-be-ZNE homes *for the same price as their prior designs for non-ZNE homes!* And it has given them a very favorable market position.

Thrive CEO Gene Myers says, "Zero energy has done more to define our brand than any other strategy we have used. Various programs that incrementally reduce energy consumption lack the impact of zero energy. We call it the Power of Zero. The Company is now focused on driving the cost of ZNE down even further in reaction to escalating costs for solar, steel, and lumber and their resulting effect on affordability." He also reports that their market leadership has led to preferential invitations to develop on choice parcels of land. That's competitive advantage and a good return on investment.



**Thrive CEO
Gene Myers
says, "Zero
energy has
done more
to define our
brand than
any other
strategy we
have used."**

Similarly, *Urban Land* reports, “Meritage was one of the first homebuilders to pursue net-zero homes at scale, and is currently the leading major homebuilder developing ‘ZNE-ready’ homes ... For customers, the return on investment starts on day one, since Meritage charges about the same per square foot for these houses as the company’s less energy-efficient peers charge for theirs. Meritage spends a little more on these homes, but believes that the additional cost is an investment in its marketing efforts – helping the homes sell faster and helping the company grow in an increasingly energy efficiency – and sustainability-conscious market.

“Meritage also found that its net-zero-ready design helped ‘future-proof’ its manufacturing model for increasingly rigid building codes: ‘California’s new construction codes and Title 24 had no disruptive impact,’ [said C.R. Herro, Meritage’s vice president of environmental affairs]. ‘Having our standards in place helped us avoid any disruption in manufacturing to retool for increasingly stringent regulations.’”²

You, as the builder, are in the best position to evaluate these tradeoffs; to assist you in doing so, we have provided a comprehensive list of the relevant factors in Table 2-1. Sections 3 through 6 provide more information about these factors, including relevant details, specifications, and references to additional resources.

Gaps in the Contract Documents

ZNE features, strategies, or specifications must be *seamlessly integrated into the contract documents (CDs)*. This means the information needs to be included in the customary place in the CDs – not in a separate, special location that is out of context. For example, advanced framing requirements need to be included with other wood framing provisions; blower door testing requirements need to be included with other quality management provisions.

Incorporate the necessary ZNE information using whichever approach is normal for your company, whether in the drawings, specifications, and/or scopes of work.

It may be helpful to call special attention to ZNE items (i.e., deviations from standard practice) in the CDs with large type, highlighting, call-outs, etc.

It is typically NOT a successful strategy to put ZNE items in a separate list, apart from related specifications – it is very likely they will be overlooked or create conflicts with information elsewhere in the CDs.

EXAMPLE: How to include airtightness/air sealing information (see more about air sealing, including a sample air barrier section drawing and details, in Section 3):

- Include the specification for airtightness (e.g., 1.5 ACH₅₀) with other enclosure specifications;
- Provide a section drawing showing a continuous air barrier around the entire building section;
- Show the correct means of air-sealing specific areas in architectural details.

Tendency to Default to Standard Practices

There is always time pressure to complete work on time and on budget. This means it is very easy for workers in the field to approach their work in the standard way, overlooking special or unusual ZNE requirements. This is a very common challenge to changing standard practices to ZNE or high-performance practices.

Meritage charges about the same per square foot for these ZNE houses as the company’s less energy-efficient peers charge for theirs.

² “How Residential and Office Developers Are Preparing for the Realities of Net Zero,” *Urban Land*, March 12, 2018. https://urbanland.uli.org/sustainability/residential-office-developers-preparing-realities-net-zero/?utm_campaign=SDU&utm_source=hs_email&utm_medium=email&utm_content=61410292&_hsenc=p2ANqtz--H5MPTdJvxoe_GyW8UjgBZh87DST0suAdqZ2LuS3vo-UAj3hNLp-qcF2T9RYnnrUzgt5gJTOUhsuqdnLYII9vkSPsZg&_hsmi=61410292

The best CDs in the world can't prevent this. However, they are important because CDs are contractual obligations and can be enforced, if the information provided is explicit enough. Construction workers aren't the only ones subject to time pressures, though, so incorrect work – so long as it isn't actually illegal or unsafe – is often let go, and this can cause reductions in performance that can sabotage the ZNE goals.

The best safeguards against this unintentional performance sacrifice are:

- Structured quality management processes
- Training crew members to perform diagnostic themselves, so they develop a better grasp of performance requirements and how to meet them cost-effectively
- Pre-task briefings and/or demonstrations targeting the likely tasks where default practices may occur (for example, air sealing and insulation installation are common problem areas where briefings and demonstrations may be helpful – see Implementation Timeline, below)
- Field checks during and immediately after performance of those targeted tasks.

IMPLEMENTATION TIMELINE

The earlier you start to factor ZNE into your development process – and particularly in goal-setting – the more easily you will implement changes that facilitate achieving ZNE performance.

Conversely, the later in the process you start, the more difficult (and expensive) it becomes to make changes. This concept is shown below, in Figure 2-1.

Figure 2-1. Cost and effort of design changes as project progresses.

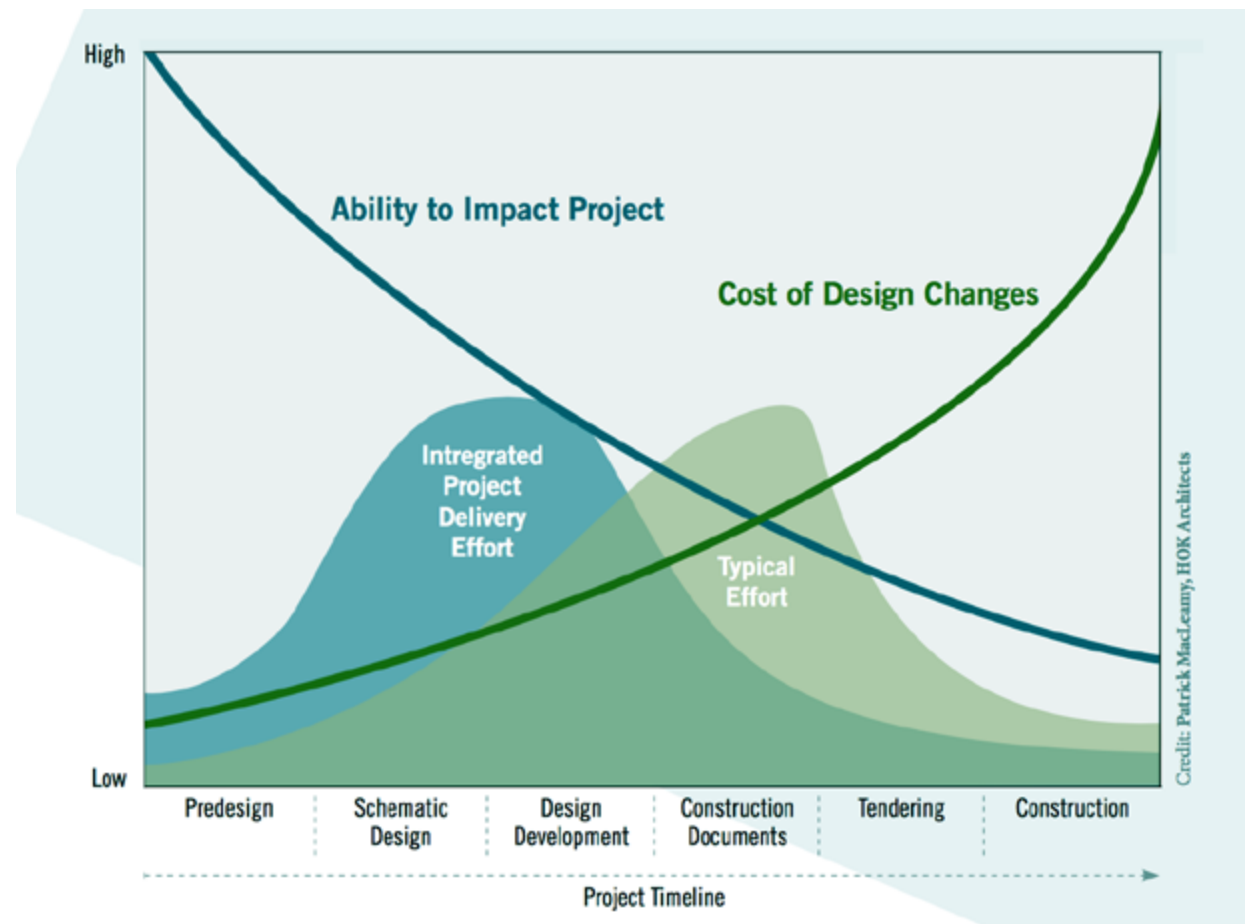

(Courtesy of Commission for Environmental Cooperation, <http://www3.cec.org/islandora/en/item/11661-improving-green-building-construction-in-north-america-guide-integrated-design-en.pdf>)

Table 2-2. Critical points in ZNE timeline

Further, at key points during design and construction, your actions will strongly influence your success in achieving ZNE and the ease with which you achieve that success. For example, developing a floor plan that includes many ‘bump-outs’ has reverberations through to the roof plan, which in turn affects space and orientation for PVs. A late decision to incorporate a heat pump water heater may prove challenging to accommodate due to the larger space needs of those units.

Table 2-2, below, outlines specific points at which ZNE-related design decisions need to be made and at which construction tasks need to be correctly executed to achieve ZNE performance goals. At each of those key points, the table identifies the topics requiring focus and who in the organization needs to participate to ensure successful achievement of your company’s ZNE goals.

Not all measures will be achievable on all sites; some may be hard to implement on a given lot, or for all homes within a subdivision – particularly when early decisions, such as the subdivision layout – have already been made.

Activity	Timing	Tasks & Focus Areas	Critical Team Members
Subdivision/lot layout	Planning	Ideally, long dimension of lots runs E-W (residential streets run N-S)	Developer, city, master planner/architect
Fuel selection	Pre-design	Evaluate approach with lowest infrastructure cost, operating energy cost, and carbon content	Developer, energy analyst
Programming	Schematic design	Include adequate area for mechanical equipment in conditioned space	Architect, drafter
House & roof form	Schematic design	Keep surface-to-volume ratio low, ensure a dequate S/SW-facing roof	Architect, marketing and/or purchasing
Floor plan & elevation development, including fenestration	Schematic design	Factor in shading, compact hot water layout, compact mechanical layout, advanced framing principles	Architect, drafter
Enclosure system specifications	Schematic design	Ensure that wall thickness, if > standard, is accounted for	Architect, drafter
Mechanical system selection	Design development	Ensure equipment capacity is matched to loads and layouts are compact and straightforward	Mechanical consultant/HVAC sub (ZNE-savvy!)
Specifications for windows, mechanical systems, etc.	Design development	Space conditioning, water heating, and ventilation systems; window U-factor and SHGC	Architect, drafter, energy onstantant, HVAC system designer
Section showing continuous air, water, and thermal barriers	Design development	All changes of plane and changes of assembly (e.g., heads, sills, jambs at openings)	Architect, drafter
Air sealing details	Design development	All changes of plane and changes of assembly (e.g., heads, sills, jambs at openings)	Architect, drafter

(cont)

Table 2-2. Critical points in ZNE timeline (cont)

Activity	Timing	Tasks & Focus Areas	Critical Team Members
ZNE briefing	Pre-construction (and ideally, during design development)	All-hands meeting: review ZNE (new and/or non-standard) requirements with all subs	Project manager, site superintendent, all affected trades (framing, air sealing, insulation, HVAC), architect, ZNE/energy consultant
Advanced framing briefing	Immediately before wall framing starts	Review new and/or non-standard measures on drawings, provide demonstrations as needed	Project manager, site superintendent, framing sub & workers
Air sealing demonstration	After framing is complete, before sheathing	Review new and/or non-standard measures on drawings, demonstrate use of materials and methods, notify regarding contractual obligations (e.g., airtightness spec)	Project manager, site superintendent, designated air sealing sub & workers
Insulation briefing	First day of insulation installation	Review quality insulation installation requirements and manufacturers' specs, notify regarding contractual obligation to meet inspection requirements	Project manager, site superintendent, insulation sub & workers
Blower door demonstration & testing	As soon as conditioned space can be completely sealed	Working with the air sealing workers, conduct initial blower door test; identify leaks and seal; retest and repeat as needed to meet targeted airtightness specification	Project manager, site superintendent, designated air sealing sub & workers
HVAC system and enclosure commissioning	As soon as HVAC system components are operational	Conduct full battery of commissioning tests and record results – see example in Table 4-3	Project manager, site superintendent, HVAC sub & workers



GETTING TO ZNE RESOURCES

For live links to the online resources below, download the PDF version of this document at pge.com/zne.

Quality Management System Guidelines,
US Department of Energy,
https://www1.eere.energy.gov/buildings/residential/pdfs/ba_in_3.1.9_qualitymanagementsystems_100213.pdf

Builders Challenge Quality Criteria Support Document, US
Department of Energy,
http://www.pnnl.gov/main/publications/external/technical_reports/PNNL-18009Rev1.3.pdf.

Four Scopes of Work for High Performance Homes,
NAHB Research Center,
http://www.homeinnovation.com/trends_and_reports/featured_reports/scopes_of_work

Various quality management documents,
NAHB Research Center,
http://www.homeinnovation.com/trends_and_reports/report_search;
click on “Quality Assurance” in topics list on left side of page.

**At the most basic level,
achieving ZNE is about
two things:**

- 1. Reducing demand
by improving energy
efficiency, cost-effectively.**
- 2. Supplying the
remaining demand
with renewable energy.**



SECTION 3. ENVELOPE

ENVELOPE ZNE STRATEGIES

The building envelope offers a variety of potential ZNE strategies, each of which is discussed in this section:

- Form factors
- Envelope specifications
- Roof & attic
- Walls – advanced framing
- Other resource efficiency measures
- Airtightness and air sealing
- Cavity insulation
- Continuous insulation
- Windows and shading

Form Factors

Many factors influence house form and have to be factored into a design, but simpler forms – including simple roof forms – lend themselves best to ZNE performance. This is because:

- Simpler forms have less surface area for heat loss and gain;
- Simpler forms are easier and cheaper to design and detail;
- Simpler forms are faster and cheaper to frame;
- Simpler forms are easier and cheaper to air-seal and insulate flawlessly;
- Simpler forms are less likely to present risks of leakage and associated damage and liability;
- Simpler forms have more contiguous roof area available for PVs;
- Simpler forms lend themselves to more aesthetically pleasing, rectangular PV arrays, rather than unsightly, chopped-up arrays.

In short, they tend to save money, reduce risk, and perform better than their non-ZNE cousins. This doesn't mean every ZNE home has to be a simple box. It just means that a straightforward, elegant form will work better than a highly elaborate one. To see a wide variety of examples, browse the resources listed on page 30. One example by KB Home is shown below.



Dawn Creek Zero House 2.0, Lancaster, CA
KB Home, 2013

Envelope Specifications

Envelope specifications have a strong influence on overall home energy efficiency, and many envelope measures afford cost-effective opportunities for performance improvements. Table 3-1 shows the envelope packages of two production builders participating in ZNE demonstrations and may provide inspiration for changes to your own specifications, depending on your unique needs and climate requirements.

Table 3-1. Sample ZNE envelope specifications

		HABITAT FOR HUMANITY OF SAN JOAQUIN COUNTY	PULTEGROUP
ENVELOPE			
■ EXTERIOR WALLS	cavity R value, insulation type framing type, spacing continuous insulation	R-21 denim 2x6, 24" oc, 0.13 framing factor R-5 XPS	R-15 Fiberglass 2x4 16" oc R-4 XPS
■ GLAZING	U/SHGC window to wall ratio (WWR) shading skylights	0.27 U / 0.24 SHGC 6.4% WWR 1' eaves no skylights	.32 U/ .25 SHGC 15% WWR no skylights
■ ROOF	insulation type, R value insulation location vented/unvented attic radiant barrier roof material reflectance / emittance	R-42 cellulose attic floor vented attic radiant barrier composite shingles	R-38 under roof deck unvented attic no radiant barrier tile
■ FOUNDATION	type insulation framing type, spacing	low ventilation crawlspace (0.5 ACH) R-21 denim 4X6, 32" oc	slab 4X6, 32" oc
■ AIR LEAKAGE	ACH ₅₀	1.5	4.9

Envelope specifications have a strong influence on overall home energy efficiency, and many envelope measures afford cost-effective opportunities for performance improvements.

Roof/Attic

Below are principles to keep in mind while designing the roof and attic.

- Keeping the number of roof planes to a minimum will provide the most roof area for PVs and result in the least expense for design, detailing, and construction – thus gabled and shed forms lend themselves to ZNE more readily than hips, dormers, and other more complicated forms.
- Ensure that you have sufficient roof space for PVs, facing south or southwest. In most California climates, for homes of average sizes (1,800 – 2,800 square feet), 200-500 square feet should be enough PV space for a highly efficient (ZNE) home. (A 1-kW PV array occupies about 80 square feet.)³
- Include required edge clearances when calculating the area needed for PVs, to be sure to meet building and fire codes. (This is in addition to the area needed for the array itself).
- Consider using raised-heel trusses, to allow the full depth of insulation to extend out to the wall edge.
- Try to locate venting where it will not interfere with PV placement or compromise insulation performance – e.g., in gable ends, at the ridgeline, or on non-PV surfaces.
- Locate access hatches where they will not compromise insulation performance – e.g., in the wall between the house attic and the garage, or in the ceiling over an uninsulated porch.
- Plan ducting runs within the conditioned space – i.e., not in an unconditioned attic – whenever possible. Often it is possible to drop the ceiling in a hallway to accommodate ducts. When ducts are in the attic, consider trusses with a plenum space that can be insulated around or putting the insulation at the roof deck.



Residence 210i Zero Energy Home at Sierra Crossing, Clovis, CA
Michael Rupard, De Young Properties, 2017
Brett Nelson photo

**In most California climates,
for homes of average sizes
(1,800 – 2,800 square feet),
200-500 square feet should
be enough PV space for a
highly efficient (ZNE) home.**

³This is using the PV array's AC rating, which is lower than the DC rating to reflect real-world vs. ideal conditions. The space requirement using the array's DC rating is approximately 70 square feet per kW.

Walls – Advanced Framing

“Advanced framing” (also known as “optimum value engineering”) comprises a set of efficiency practices that reduce the amount of framing materials, as well as labor, in light wood-frame construction – also resulting in cost savings and energy savings. Adopting advanced framing practices requires an initial investment of time in design and engineering, along with framing crew training. Production home building is the ideal environment for advanced framing, where the initial investment will yield paybacks in cost and energy savings over multiple units.

In a study by the National Association of Home Builders Research Center (NAHBRC), lumber savings for a house designed with a suite of advanced framing measures were estimated between 8 and 30 percent when compared with five different houses designed without advanced framing.⁴ Lumber savings represent less material to haul, cut, nail, etc. – i.e., labor savings. In the Habitat for Humanity home described in *PG&E Stockton*, just one advanced framing measure, changing the wall framing from 2x4 @ 16” o.c. to 2x6 @ 24” o.c., although it resulted in no significant change in material costs, reduced framing time by 12 hours, saving \$300.

Well-established – albeit not widely adopted – advanced framing measures include:

- Framing at 24 inches on center, rather than at 16 (see Figure 3-1)
- Aligning openings with stud spacing (see Figure 3-1)
- Single top plates (see Figure 3-2)
- Headers engineered for the specific loading conditions (and no headers in non-bearing walls)
- Eliminating unnecessary framing at intersections, and using drywall clips (see Figure 3-3)

The R-value of framing lumber is less than one-third that of high-density fiberglass batt insulation.⁵ Thus advanced framing, by reducing the amount of framing lumber in the envelope, also improves thermal performance by reducing thermal bridging – the transfer of heat from one side of the enclosure to the other (from the interior to the exterior or vice versa).

Adopting advanced framing practices requires an initial investment of time in design and engineering, along with framing crew training.

⁴ NAHBRC, *Residential Construction Waste Management Demonstration and Evaluation Task 2 Report*, 1996.

⁵ ColoradoEnergy.org, <http://www.coloradoenergy.org/procorner/stuff/r-values.htm>

Figure 3-1. 24-inch-on-center framing with opening aligned with stud spacing (Courtesy of Bruce King)

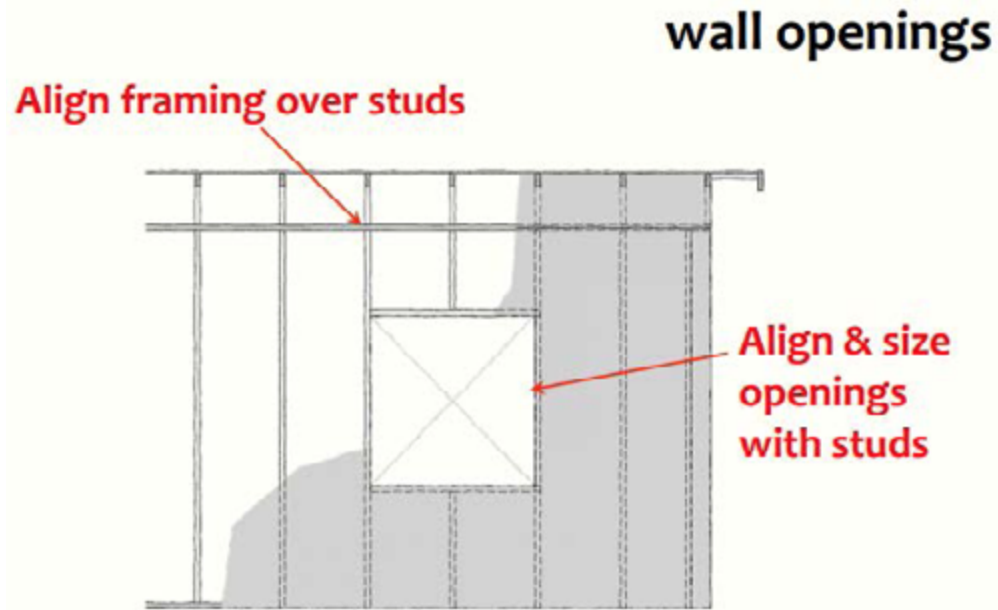

Figure 3-3. Drywall clips (Courtesy of Building Science Corporation)

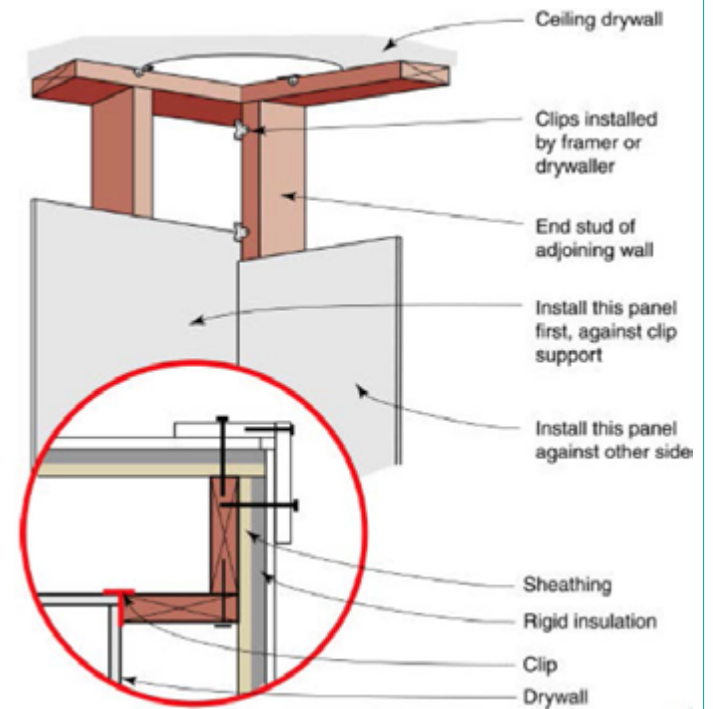
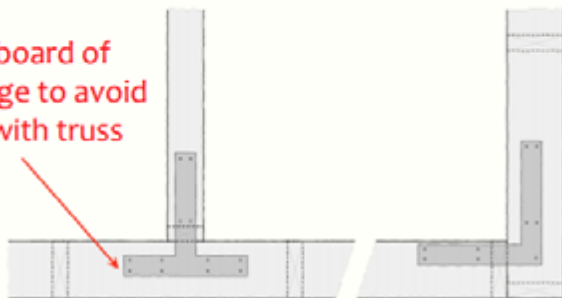

Figure 3-2. Single top plate (Courtesy of Bruce King)

single top plate

light gauge metal “T” and “L” straps connect plates

Install inboard of outer edge to avoid conflict with truss blocking



single top plate

light gauge metal “T” and “L” straps connect plates

Install inboard of outer edge to avoid conflict with truss blocking

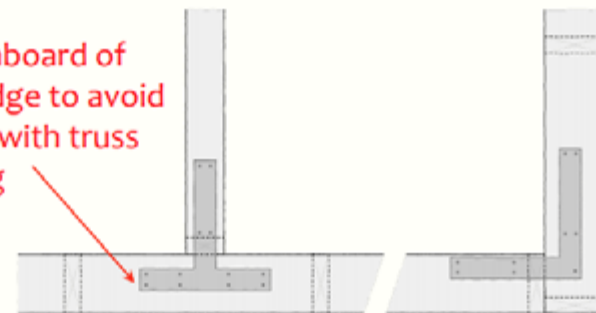

A typical new California home has a framing factor as high as 35% – that is, 35% of the wall surface area is occupied by framing lumber. However, careful planning can make it possible to reduce the framing factor to as little as 12.5%, depending on the size and complexity of the home. In the Habitat for Humanity example cited above, a comprehensive set of advanced framing and other resource-efficiency strategies increased the effective R value of the wall by 17% and resulted in a net savings of nearly \$3,000 – even while achieving ZNE performance.

Some of the more 'advanced' of the advanced framing measures used in the Stockton demonstration are illustrated in Figures 3-5 to 3-12.

Figure 3-4. Engineered header with raised-heel truss (Drawing courtesy of Bruce King)

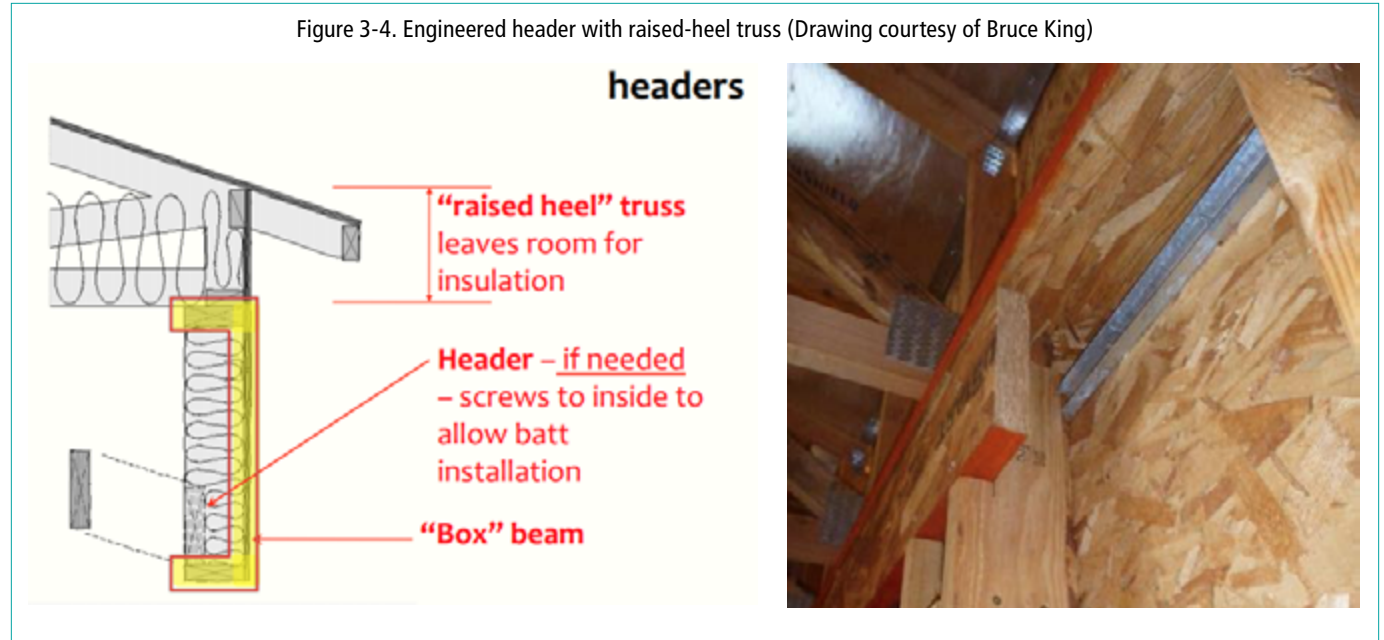

Figure 3-5. Raised heel trusses



Successful implementation of advanced framing – because it represents a deviation from framers’ normal practices – requires providing clear guidance in construction documents: structural framing plans (which are relatively standard practice) and elevations (which are not). Figure 3-9 shows an example of both; note that the framing elevations show every stud. You may also encounter resistance from your local building department. Builders have reported addressing their concerns successfully by citing applicable sections of the building code on their drawings. The engineered single top plate assures that the wall is straight. No joints are typically needed since this material can be purchased in lengths up to 60 feet.

Engineered window and door headers maximize the space for insulation and eliminate the thermal bridge that solid headers create. Headers are temporarily installed with screws so they can be removed to install insulation, defect-free, behind them.

Figure 3-6. Attic access in garage – not penetrating ceiling insulation



Figure 3-7. Engineered single top plate, from above



Figure 3-8. Engineered headers

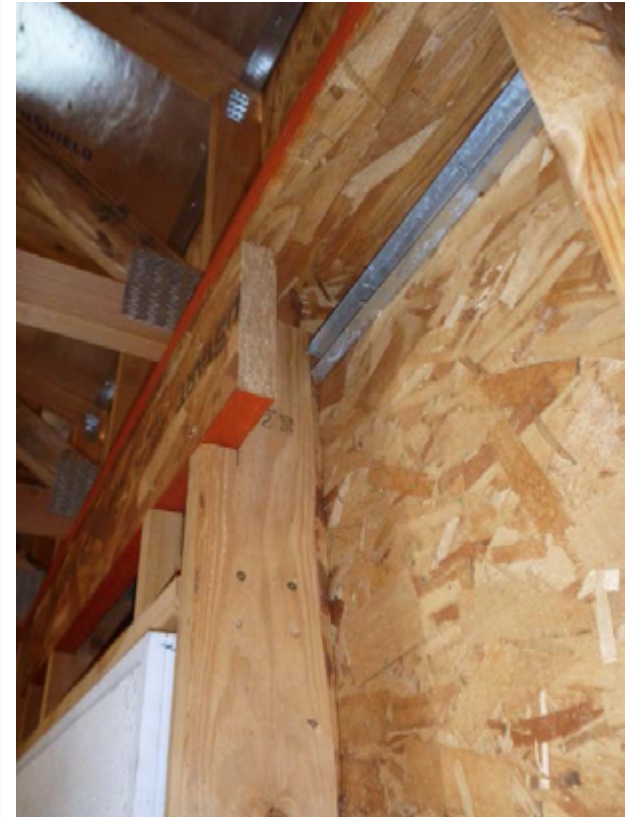
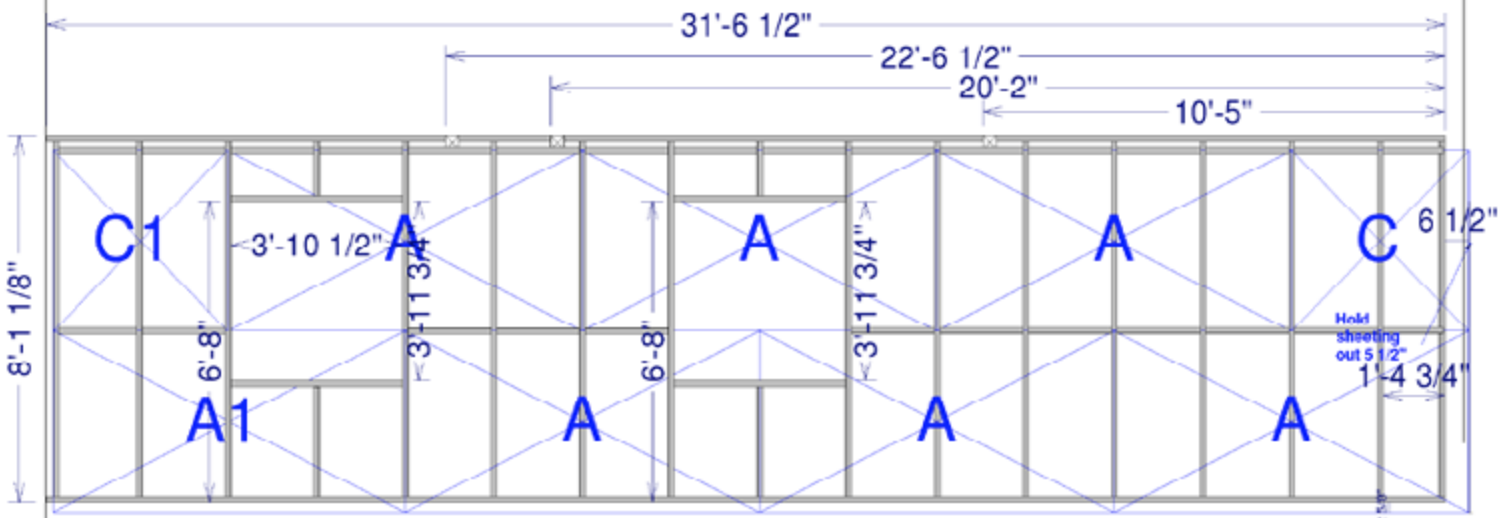
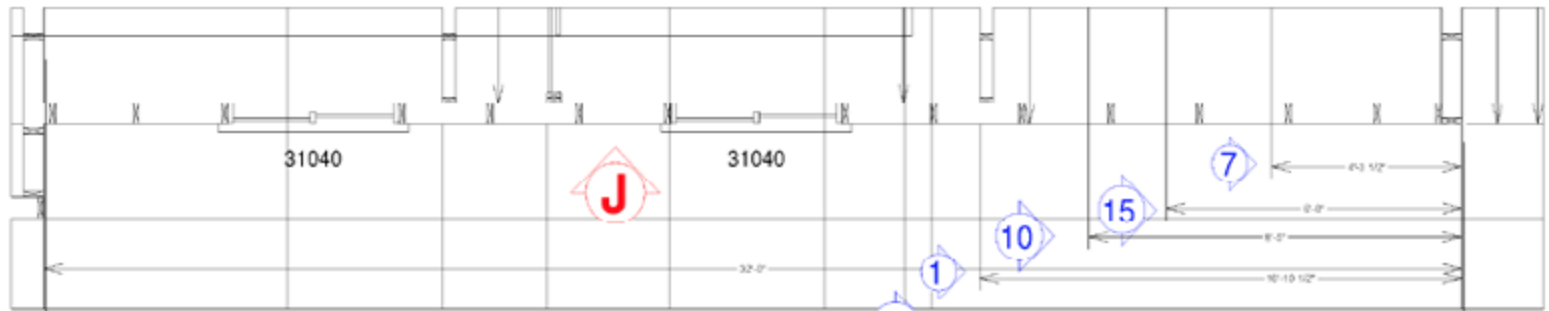

Figure 3-9. Advanced framing wall plan and elevation (Courtesy of Habitat for Humanity – San Joaquin)



Studs and sheeting out back 1 1/2" for wall K notch K sheeting and foam for bottom plate

Wall	Size	Part	amount	Feet	inches	1/16
J	2x6	Top & bottom plate	2	31	6	8
J	2x6	Studs	15	7	10	2
J	2x6	Top crippels window	2	1	2	2
J	2x6	Bottom crippels 40	2	2	5	4
J	2x6	Sill	4	3	10	8
J	1/2" OSB	Sheet A	5	8	0	0
J	1/2" OSB	Sheet A1	1	7	11	6
J	1/2" OSB	Sheet C	1	4	0	0
J	1/2" OSB	Sheet C1	1	3	11	6

WALL J

Other Resource Efficiency Measures

In the PG&E Stockton ZNE project mentioned above, some of the net savings were due to innovations that went beyond established practices in advanced framing and resource efficiency. A number of these measures are shown in Figures 3-10 through 3-12.

The industry standard installation technique is to cut drywall so that a sheet ends on a framing member to which the end of the sheet is attached. Instead, using drywall splices (4-inch-wide scraps placed behind joints where two pieces come together) avoids the need to measure and cut a piece of drywall, until reaching the end of the wall. Benefits include:

- Reduced material cost because of less waste
- Reduced labor – less measuring and cutting
- Reduced waste disposal cost
- Easier to finish, since there are more factory sheet edges
- Stronger joints, since joints have 2 inches rather than $\frac{3}{4}$ " of backing

Figure 3-10. Ground-constructed gable-end truss assembly being craned into place



Figure 3-12. Studs pre-drilled for wiring



Figure 3-11. Drywall splicing



Airtightness and Air Sealing

Controlling air leakage is a critical aspect of building a ZNE home. Uncontrolled air leakage can reduce the thermal resistance of a well-insulated building enclosure by 15 to more than 30 percent, as well as increasing risks of condensation, rot, and mold formation – and associated liability. The better the targeted insulation levels, the lower the target air leakage should be.⁶

In a ZNE home, it is important to include a mechanical ventilation system to supply fresh, filtered air at an appropriate rate for the size of the home. Mechanical ventilation avoids air quality problems and greatly reduces the energy penalty of uncontrolled air leakage – even after accounting for the fan energy.

Leaks are controlled by air sealing – applying sprays, tapes, mastics, foams, and/or other barrier materials to penetrations from conditioned space to unconditioned spaces and to the outdoors, to eliminate or greatly reduce uncontrolled air movement. Air sealing is an uncommon skill and not yet well-established as a trade in the US. There also are very few architects who are familiar with the

materials and practices of air sealing. As a result, this is among the most challenging aspects of building ZNE homes – and thus requires more attention by the builder than almost anything else, once the basic design has been developed.

Design Phase

Successful air sealing requires including the following information in the contract documents:

- Specification for airtightness and accountability for outcomes; include in relevant sections (e.g., specify in Facility Shell Performance Requirements)
 - + Passive House requires achieving airtightness of 0.6 ACH₅₀
 - + 1 CFM50 per thousand square feet of floor area (e.g., 2 ACH₅₀ for a 2,000-square-foot home) is considered average for a reasonably tight home; 1.5 ACH₅₀ is an excellent target for ZNE homes in most California climates
 - + Title 24-2016's new construction defaults for single-family build-ings and townhomes are 4.4 ACH₅₀ if there are no ducts in unconditioned space, 5 ACH₅₀ if there are ducts outside of conditioned space.

- Architectural details showing the correct means of air-sealing specific areas – an example is shown in Figure 3-13; note the precise indication of where to place sealant, and what type of sealant
- Section drawing showing a continuous air barrier around the entire building section – see example in Figure 3-14, with a detail called out for every change of assembly or change of plane
- When and how airtightness should be tested (e.g., specify in Field Quality Control Procedures)

Construction Phase

In addition, successful air sealing requires extreme vigilance during construction. Some of the key requirements include:

- Assign specific responsibility for air sealing to one individual (air sealing manager, or ASM) who reports to the site superintendent or project manager
- Ensure that the ASM receives specific training in effective air sealing techniques and in blower door testing (see resources listed below)

⁶ John Straube, PhD, RDH Building Science, personal communication, 4/3/18.

- Brief all affected workers/subs (e.g., framing, windows, plumbing, electrical, drywall) on the importance of air sealing to the ZNE goal, and inform them that they are answerable to the ASM for their specific contributions to the overall air sealing strategy
- Demonstration by the ASM of specific techniques the subs will use
- Frequent inspections by the ASM as trade work involving air sealing proceeds
- A preliminary blower door test conducted by the ASM as soon as the house is fully closed in, i.e., after all exterior windows and doors are installed; after rough plumbing, electrical, and all other penetrations in the pressure boundary are complete; and preferably before any materials cover the exterior sheathing and/or shear walls and before any insulation or drywall is installed
- Use of appropriate diagnostic techniques (e.g., smoke testing) to identify leak sources
- Correction of air sealing defects
- Additional blower door testing during and post-correction activities until the targeted airtightness is achieved

Figure 3-13. Detail 3 and air sealing key from continuous air barrier drawing (Courtesy of Coldham & Hartman Architects)

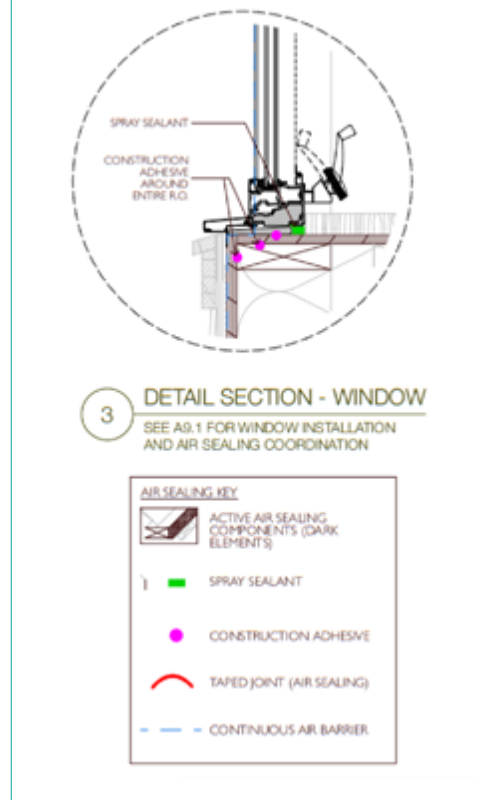
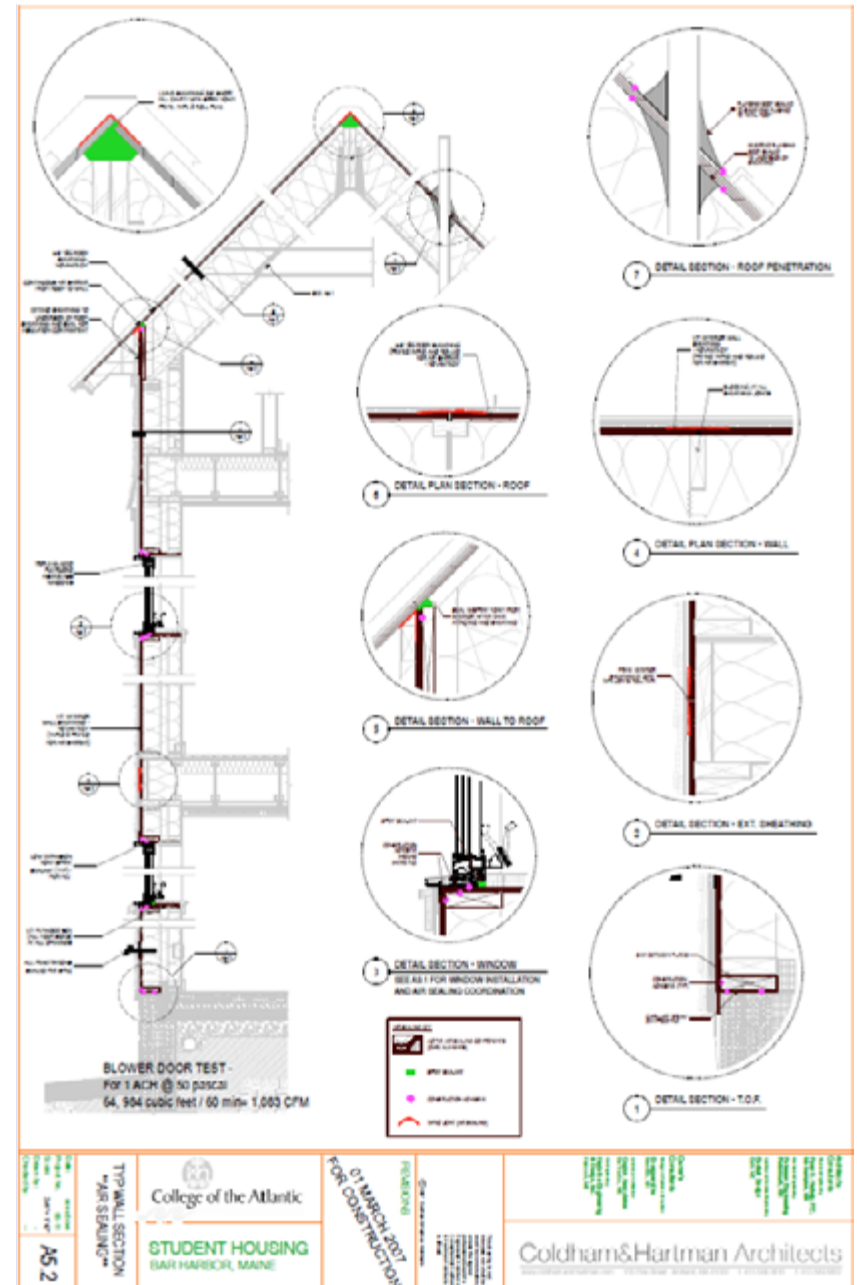

Figure 3-14. Continuous air barrier drawing (Courtesy of Coldham & Hartman Architects) (The drawing can be downloaded at <http://www.candharchitects.com/projects/college-of-the-atlantic-kathryn-w-davis-student-village/>; see link to "A5.2 Wall Section Air Sealing Drawing".)



Cavity Insulation

Installing cavity insulation is perhaps the most mundane of construction activities. It is also a trade that is commonly executed poorly due to low bid-induced haste and ignorance as to the damages caused by low-quality installation. Installation defects greatly reduce the overall effectiveness of the envelope, increase utility costs, cause comfort problems, and – like air leakage – may lead to condensation and mold.

Quality installation is an absolute must for ZNE projects, as it is a foundation of efficient performance. In simplest terms, quality installation consists of installing insulation in full contact with all six faces (back, front, top, bottom, and both sides) of every exterior surface framing cavity, and compliance with all manufacturers' installation specifications. Any type of insulation can be installed well or poorly, but batt insulation requires the greatest attention to detail to avoid the common defects of gaps and compression. Alternative cavity insulation materials include blown fiberglass, cellulose, wool, cotton, and spray foams. Each material has its pros and cons, as described in the Building-Green resource listed below.

Activities essential to getting insulation installed well include:

- Provide clear specifications requiring compliance with California "Quality Insulation Installation" (QII) standards – see resources listed below
- Pre-installation briefing of installers as to the quality expectations
- Close onsite supervision during installation
- Rigorous post-installation quality assurance (e.g., inspection against QII or HERS Grade I standards)

Continuous Exterior Insulation

With the evolution of the California energy code, and in many other places due to climate, continuous exterior insulation (also called insulating sheathing, rigid board insulation, or board insulation) is increasingly seen as an essential component of the envelope. There are several basic types of insulating sheathing:

- Expanded polystyrene (EPS)
- Extruded polystyrene (XPS)
- Polyisocyanurate (polyiso)
- Mineral wool
- Cork

Including continuous exterior insulation entails some changes of practice that initially may prove challenging.

A few of those changes include:

- Ordering windows and doors with deeper frames to accommodate the added wall thickness
- Choosing fasteners for attachment of the board insulation
- Proper attachment of siding over board insulation
- Proper detailing at openings

Several of the resources listed below provide information to help with product selection and installation.

Factors to consider in choosing the type of rigid board include:

- R-value, including aged R-value
- Environmental and health performance
- Installation methods and other construction and handling characteristics

Quality installation is an absolute must for ZNE projects, as it is a foundation of efficient performance.

Windows and Shading

Windows are an important aspect of home design – they are a major factor in the aesthetic appeal of a home, both indoors and from the outside. They also may have potentially profound effects on both energy performance and comfort. The ideal window design will balance needs for daylight and access to desirable views with control of privacy, heat loss through glass in the winter, heat gain in the summer, and operability (or not, as appropriate).

A home without enough windows feels claustrophobic and unappealing, but in well-insulated ZNE homes, too much glass – particularly facing west and/or south – can cause drastic overheating, particularly in spring and fall when sun angles are low and bypass overhangs. This can put a huge load on the cooling system and make occupants extremely unhappy. Therefore, it is critically important to ensure that window specifications – SHGC in particular, as well as U-factor – are appropriate for the climate. Budget-motivated compromises in window specs can have highly adverse performance consequences.

Other key design measures to consider in ZNE homes include shading and glare protection strategies, and using skylights judiciously. Shading glass can substantially reduce risks of excess heat gain, when effectively designed to avoid or minimize direct beam sunlight on windows during key times of day (midday and late afternoon) and times of year (summer, but also spring and fall, when sun angles are low and temperatures warm). Well-designed shading can also help minimize interior glare. Skylights are challenging in most California climates, due to the difficulty of preventing unwanted heat gain during daylight hours, and excess heat loss at night and in winter.

The ideal window design will balance needs for daylight and access to desirable views with control of privacy, heat loss through glass in the winter, heat gain in the summer, and operability (or not, as appropriate).

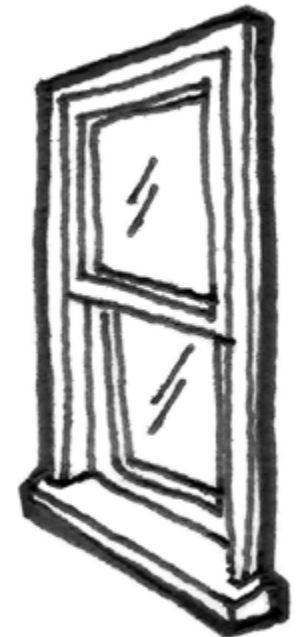

ENCLOSURE RESOURCES

For live links to the online resources below, download the PDF version of this document at pge.com/zne.

FORM FACTORS

Net Zero Energy Coalition/Northeast Sustainable Energy Association Case Study Database,
<http://www.nesea.org/buildingenergy-case-studies>

US Department of Energy Tour of Zero,
<https://www.energy.gov/eere/buildings/doe-tour-zero>

ROOF/ATTIC

<http://www.greenbuildingadvisor.com/blogs/dept/building-science/use-plenum-trusses-keep-ducts-out-your-attic>

WALLS – ADVANCED FRAMING

Appendix 3, *PG&E Stockton – Final Report*, March 2017, Pacific Gas and Electric Company Zero Net Energy Production Builder Demonstration, Habitat for Humanity of San Joaquin County Dream Creek Subdivision, Stockton, CA. Free download at <https://www.etcc-ca.com/reports/zero-net-energy-production-builder-demonstration>

Light Wood Framing for Efficiency and Economy. Bruce King, PE. Free download at <http://www.ecobuildnetwork.org/images/pdfs/Framing-Efficient-King.pdf>

Chapter 11, *Builder's Guide to Hot-Dry & Mixed-Dry Climates* (print), Joseph Lstiburek, Energy & Environmental Building Association, 2004; or *Builder's Guide to Mixed-Humid Climates* (download), Joseph Lstiburek, Building Science Corporation, 2009⁷, <https://buildingscience.com/bookstore>

Advanced Framing Research Report – 0113. Building Science Corporation, October 2001.

Construction Guide, Next Generation High Performance Walls, Climate Zones 3-5 Part 1: 2x6 Walls. Home Innovation Research Labs, January 2016. Free download at <https://www.homeinnovation.com/~media/Files/Reports/Construction-Guide-to-Next-Generation-High-Performance-Walls-in-Climate-Zones-3-5-Part-2-2x4-Walls.pdf>

Advanced Framing Construction Guide. APA, 2012. Free download at <https://www.apawood.org/publication-search?q=M400&tid=1>

OTHER RESOURCE EFFICIENCY MEASURES

Appendix 3, *PG&E Stockton – Final Report*, March 2017, Pacific Gas and Electric Company Zero Net Energy Production Builder Demonstration, Habitat for Humanity of San Joaquin County Dream Creek Subdivision, Stockton, CA. Free download at <https://www.etcc-ca.com/reports/zero-net-energy-production-builder-demonstration>

Light Wood Framing for Efficiency and Economy. Bruce King, PE. Free download at <http://www.ecobuildnetwork.org/images/pdfs/Framing-Efficient-King.pdf>

AIRTIGHTNESS & AIR SEALING

Chapter 3, *Builder's Guide to Hot-Dry & Mixed-Dry Climates* (print), Joseph Lstiburek, Energy & Environmental Building Association, 2004; or *Builder's Guide to Mixed-Humid Climates* (download), Joseph Lstiburek, Building Science Corporation, 2009⁷, <https://buildingscience.com/bookstore>

⁷ To determine which *Builder's Guide* is applicable to your location, consult a *non-California* climate zone map, e.g., Energy Vanguard, Do You Know Your Building Science Climate Zone?, <http://www.energyvanguard.com/blog/59387/Do-You-Know-Your-Building-Science-Climate-Zone>.

ENCLOSURE RESOURCES (cont)

Air Sealing to Achieve Zero Net Energy, offered at PG&E Energy Centers in San Francisco and Stockton, <https://www.pge.com/pec>.

Fact Sheet: Envelope Air Sealing 2013 California Energy Efficiency Building Standards, California Energy Commission, <http://www.energy.ca.gov/2014publications/CEC-400-2014-024/CEC-400-2014-024-FS.pdf>

Revisions to Quality Management Products: Four Scopes of Work for High Performance Homes – NREL, National Association of Home Builders Research Center – covers excavation, foundations, framing, and HVAC, including recommended specification language, http://www.homeinnovation.com/trends_and_reports/featured_reports/scopes_of_work

Ace Installation Residential, Energy Code Ace – covers air sealing, insulation, HVAC, plumbing, and more https://energycodeace.com/download/16520/file_path/fieldList/2016%20Installation%20Ace_Res_Complete%20Guide.pdf [auto download]

Hammer and Hand Best Practices Manual, <https://hammerandhand.com/best-practices/manual/>.

Various classes offered at Southern California Edison’s Energy Education Centers, <https://www.sce.com/wps/portal/home/business/consulting-services/energy-education-centers>. Air sealing and blower door testing are taught in IHACI NATE certification preparation classes, HERS certification preparation classes, AC Quality classes, and ACCA classes.

Various classes offered at San Diego Gas & Electric’s Energy Innovation Center, <https://www.sdge.com/eic>.

CAVITY INSULATION

Energy Code Ace Quality Insulation Installation resources – a sample plan set including air sealing details, a QII note block to be added to architectural plans, and a contractor’s QII checklist, <https://energycodeace.com/site/custom/public/reference-ace-2013/index.html#!Documents/ra35qualityinsulationinstallationprocedures.htm>

California Insulation Stage Checklist, http://www.energy.ca.gov/2008publications/CEC-400-2008-016/rev1_appendices/appendix_A_files/Installation_Certificate_CF-6R-ENV-HERS/2008_CF-6R-ENV-22-HERS-QII-InsulationStageChecklist.pdf

Ace Installation Residential, Energy Code Ace – covers air sealing, insulation, HVAC, plumbing, and more https://energycodeace.com/download/16520/file_path/fieldList/2016%20Installation%20Ace_Res_Complete%20Guide.pdf

RESNET Batt Insulation Installation video series, <http://www.resnet.us/blog/new-how-to-video-series-on-installing-batt-insulation-to-meet-resnets-grade-i-criteria/>

Chapter 4, *Builder’s Guide to Hot-Dry & Mixed-Dry Climates* (print), Joseph Lstiburek, Energy & Environmental Building Association, 2004; or *Builder’s Guide to Mixed-Humid Climates* (download), Joseph Lstiburek, Building Science Corporation, 2009⁸, <https://buildingscience.com/bookstore>

⁸ To determine which *Builder’s Guide* is applicable to your location, consult a *non-California* climate zone map, e.g., Energy Vanguard, Do You Know Your Building Science Climate Zone?, <http://www.energyvanguard.com/blog/59387/Do-You-Know-Your-Building-Science-Climate-Zone>.

ENCLOSURE RESOURCES (cont)

Revisions to Quality Management Products: Four Scopes of Work for High Performance Homes – NREL, National Association of Home Builders Research Center – covers excavation, foundations, framing, and HVAC, including recommended specification language, http://www.homeinnovation.com/trends_and_reports/featured_reports/scopes_of_work

The BuildingGreen Guide to Insulation – each insulation type analyzed, including thermal performance (R-value), response to aging, performance in extreme temperatures, off-gassing, global warming potential, health impacts, and other key factors, <https://www.buildinggreen.com/continuing-education/insulation-report>

CONTINUOUS EXTERIOR INSULATION

Building Science Corporation, *Builder's Guide to Continuous Insulation*, http://msdssearch.dow.com/PublishedLiteratureDOW-COM/dh_0913/0901b80380913ef0.pdf?filepath=styrofoam.&fromPage=GetDoc

Buildinggreen.com, Board Insulation, including environmental performance of different rigid board types, <https://www.buildinggreen.com/product-guide/board-insulation>. (Available to subscribers, \$19.95/mo or \$199/yr.)

Greenbuildingadvisor.com video, "How to Install Rigid Foam Insulation Outside a House," <http://www.greenbuildingadvisor.com/video-how-install-rigid-foam-insulation-outside-house> (Available to subscribers, \$14.95/mo or \$149.95/yr.)

Building Science Corporation, GM-0702: Guide to Insulating Sheathing, https://buildingscience.com/sites/default/files/migrate/pdf/GM_Guide_Insulating_Sheathing.pdf

Building Science Corporation, BSI-085: Windows Can Be A Pain* – Continuous Insulation and Punched Openings, <https://buildingscience.com/documents/insights/bsi-085-windows-can-be-a-pain/>

Building Science Corporation, BSD-146: EIFS - Problems and Solutions. <https://buildingscience.com/documents/digests/bsd-146-eifs-problems-and-solutions>

US Department of Energy Building America program, Measure Guideline: Incorporating Thick Layers of Exterior Rigid Insulation on Walls, <http://www.nrel.gov/docs/fy15osti/63337.pdf>

California Advanced Homes Program Master Builder Product Catalogue, <http://cahp-pge.com/wp-content/uploads/2016/09/CAHP-Master-BUILDER-Product-Catalogue.pdf>. Produced by TRC Solutions.

BC Hydro, Building Envelope Thermal Bridging Guide, <https://www.bchydro.com/news/conservation/2014/building-envelope-thermal-bridging.html>

Roxul, stone wool insulation board attachment guide, http://www1.roxul.com/files/RX-NA_EN/pdf/Technical%20Bulletins_Guides/Commercial/CAVITYROCK_COMFORTBOARD_CLADDING_ATTACHMENT_TECHGUIDE_EN.pdf

WINDOWS AND SHADING

Efficient Windows Collaborative, <http://www.efficientwindows.org/> – in particular, window selection tools for both new and replacement windows

SECTION 4. HEATING, VENTILATION, & AIR CONDITIONING

SUCCESSFUL HEATING, VENTILATION, AND AIR CONDITIONING FOR ZNE HOMES

Successful ZNE home heating, ventilating, and air conditioning (HVAC) systems – systems that provide the best balance between installation cost and delivered performance (and require minimum energy to operate) – have several unmistakable characteristics:

- **They use proven HVAC technologies, installed by technicians who have been trained to measure the systems' installed performance.** Though not yet adopted widely, the technologies featured in this section are time-tested in the field over many decades. For example, mini-split heat pumps have been widely used in Asia and were introduced to the US market more than 40 years ago. By contrast, many US manufacturers rely on unitary equipment that may be more expensive with lower performance ratings.
- **Heating and cooling equipment capacities are small.** HVAC system design is intimately related to the quality of the thermal enclosure; an excellent thermal enclosure (i.e., low air leakage rate, quality insulation installation, high-performance windows, etc.) substantially reduces heating and cooling loads. As a result, much lower-capacity heating and cooling equipment can – and *should* – be used. In many dry California climates, this is likely to be in the range of one-fifth of the capacities typically installed in new homes today.
- **The HVAC installers know that the system they have installed performs as intended.** The only way to know about an HVAC system's performance is to measure it – and having installers make those measurements is important for affordability and to enhance their ability to perform quality installations. (HERS verifications, while useful to ensure minimum code requirements are met, are not necessarily performance tests.) Systems should be tested to assure they meet specified air flow and refrigeration requirements for the home, and not just minimum HERS requirements.
- **The air handler and the duct system are within conditioned space.**

HVAC specifications have a strong influence on overall home energy efficiency, and afford cost-effective opportunities for improvements.

HVAC Specifications

As with the envelope, HVAC specifications have a strong influence on overall home energy efficiency, and afford cost-effective opportunities for improvements. Table 4-1 shows the HVAC specifications of two production builders participating in ZNE demonstrations.

More detailed specifications for the Habitat house can be found in Table 4-3.

'Just-Right' HVAC System Design

The heating/cooling equipment sizing issue is a 'Goldilocks' problem – we want the just-right size. Equipment that is too small won't be able to satisfy the heating and cooling loads; oversized equipment is more expensive, not as good at delivering comfort, harder to fit into conditioned space, and less long lived.

For example, an oversized furnace will provide a short blast of heat (typically creating higher-than-desired temperatures in some parts of the home) and then shut off until the thermostat drops again; then this will repeat, so the occupants are alternately too warm and too cool. Furthermore, oversized, rapidly cycling equipment fails prematurely because it is designed to run continuously, not in short cycles. Similar

Table 4-1. Sample HVAC specifications

HVAC SYSTEM		HABITAT FOR HUMANITY OF SAN JOAQUIN COUNTY	PULTEGROUP
■ VENTILATION	type air flow	2ERVs 60 CFM supply, 80 CFM exhaust	exhaust
■ HEATING & COOLING	heating system type heating efficiency heating capacity cooling system type cooling efficiency cooling capacity equipment location thermostat	ducted mini split heat pump, 3/4-ton 12.5 HSPF 12,000 Btuh (10 Btu/sf) ducted mini split heat pump, 3/4-ton 24.5 SEER 9,000 Btuh (1,600 sf/ton) conditioned space (hall soffit) web-enabled, wired	heat pump, 3-ton 9.2 HSPF 33,400 Btuh (14 Btu/sf) heat pump, 3-ton 18 SEER 32,200 Btuh (780 sf/ton) semi-conditioned attic smart thermostat
■ DUCTS	location insulation leakage duct length	conditioned space (hall soffit) R-8 0 50'	semi-conditioned attic R-8 7.5%

occupant discomfort (and premature equipment failure) also occurs in the air conditioning mode.

Lower-capacity HVAC equipment – with a high-quality enclosure – is critical to achieving ZNE cost-effectively. Lower-capacity heating and cooling equipment costs less than the typical oversized equipment, and the equipment savings can help offset added costs for enclosure enhancements such as improved air sealing and insulation – while also improving comfort and reducing callbacks.

The industry standard for air conditioner sizing in California has moved from 400 square feet per ton of conditioned floor area per ton of cooling capacity in the 1970s, to 500 to 800 square feet per ton today – a reduction of about 40 percent – while loads calculated by the California Energy Commission have fallen more than 90 percent. The sizing standard needs to evolve accordingly. Table 4-2 shows examples of ZNE homes, with sizing up to 3,400 square feet per ton.

These examples demonstrate that equipment capacities three to five times lower than are typically specified will meet the heating and cooling needs of our ZNE homes.

Despite the changes over the last several decades, the industry still tends to oversize HVAC equipment. In most California locations, air conditioners for ZNE homes should be sized at between 1,500 and 2,000 square feet of conditioned floor area per ton of air conditioning, and heating equipment should be sized at 10 to 15 Btu/sq.ft. On the coldest nights of the year, if operating properly, the heating should operate more than 70 percent of the time, while still meeting the heating load. Similarly, a properly installed cooling system should run at least 70 percent of the time on the hottest afternoons.⁹

One challenge with sizing equipment that is much smaller than the industry standards can be a lack of low-capacity equipment that is needed for high-performance enclosures. In California, even a ducted mini-split heat pump – with one-quarter of the capacity of the smallest furnace available – often has too large a capacity (except in California’s mountain, desert, and north coast climate zones). This will

⁹ John Proctor, Proctor Engineering, personal communication, 2018.

Table 4-2. Sample cooling equipment sizing for California ZNE homes

Builder	Location	CA Climate Zone	Cooling Degree Days	Home Size (sq.ft.)	Cooling Load (Btu/hr)	Cooling Capacity Installed (tons)	Builder Standard Sizing (tons)	Square Feet Per Ton
Habitat for Humanity of San Joaquin County	Stockton, CA	12	1,860	1,200	6,000	0.75	2.5	1,600
CHISPA	Greenfield, CA	4	384	1,167	7,500	1.5*	2.5	778
Redding, Building America Project, 2005 Chitwood Energy	Redding, CA	11	2,549	3,500	15,000	2.0	8	1,750
PG&E Redding Demo, Energy Docs	Redding, CA	11	2,549	2,560	8,000	0.75	4	3,400

* Smallest unitary (American style) heat pump available

likely change as more ZNE homes are built, with specifications more frequently calling for lower-capacity equipment.

However, equipment sizing is not the only part of HVAC system design that challenges the industry. All other design decisions present similarly tricky ‘just-right’ engineering problems. For example:

- Supply grille sizes need to be just right. A grille that is too small is noisy; one that is too large delivers air at a velocity too low to mix the air in the room and creates temperature stratification, making the room uncomfortable.

- Duct sizes need to be just right. A duct that is large uses less fan energy to push air through it and lowers operating costs, but a large duct has more surface area and therefore increases both conductive losses and operating costs.
- Air flow rates need to be just right. Air conditioner air flow that is too low wastes energy by removing too much moisture from the air, but air flow rates that are too high don’t remove enough moisture and increase fan energy use.

Although the HVAC industry has computerized design tools (ACCA Manuals J, D and S) to help make these tricky engineering decisions, incorrect installation can severely compromise operating performance; for example, field research shows air conditioner efficiency losses alone totaling 50%:¹⁰

- Duct leakage 7%
- Duct conductive losses 12%
- Refrigerant charge and contamination 8%
- Low air flow (high latent removal) 14%
- Equipment oversizing 4%
- Room air delivery and mixing 5%

These errors are typically due to a lack of commissioning, e.g., leaving systems in the default factory setup. Commissioning entails implementing “installer settings” to correspond with the design specifications developed using the ACCA manuals. This happens very infrequently because few installers attend factory training on this process, and because bids typically don’t include time to complete required tasks such as testing the line set, line-set evacuation, and other tests and adjustments such as those shown in Table 4-3.

The “V” in HVAC Stands for Ventilation

Too often ventilation – bringing in filtered outdoor air – is viewed as a code-mandated nuisance. But as we build tighter homes (homes with less air leakage on cold windy nights), ventilation has become critical to providing good indoor air quality. Since the requirement for ventilation systems is relative new, the HVAC industry has not adopted a standard solution – and is experimenting with the many possible solutions to this mandate. Suggested criteria for ZNE home ventilation systems are listed below.

1. Consider specifying *heat recovery ventilation* (HRV) in homes, especially in the more severe California climates – i.e., those having 5,000+ heating plus cooling degree days (mountain, north coast, or desert climate zones). HRV systems are more cost-effective the more extreme the climate.
2. Install the ventilation system’s outdoor air intake in a location that is easily accessible, such that air flow can be readily measured; and where the incoming air will not be contaminated by car exhaust, excessive heat (from

a south- or west-facing wall or roof), or odor (e.g., from an asphalt shingle roof). The ceiling of a porch on the north side of the home is an example of an acceptable air intake location.

3. Consider air filtration. Title 24 requires a MERV 13 filter.
4. The system should normally operate continuously, but should have a labeled switch to turn it off in case of poor outdoor air quality, e.g., caused by a fire in the area.

HVAC Installation Quality

HVAC system installation quality also has a large impact on the delivered performance. A perfectly sized and designed HVAC system, if installed poorly, will not provide the anticipated energy efficiency, comfort, and good indoor air quality required for a successful ZNE home.

Many energy features are somewhat intuitive – you can look at wall cavity insulation filled with a spray-applied loose-fill insulation and intuitively grasp that it will perform much better than fiberglass batt installation with gaps and compressions.

¹⁰ *Efficiency Characteristics and Opportunities For New California Homes*, CEC-500-2012-062. March 2011. Prepared for California Energy Commission by Proctor Engineering Group, Ltd. <http://www.energy.ca.gov/2012publications/CEC-500-2012-062/CEC-500-2012-062.pdf>

Unfortunately, nothing about HVAC sizing, design and installation is intuitive – it’s not possible to assess delivered performance without performance measurements of the system in operation. Whether the flex duct inside liner has been stretched taut or left slack changes the static pressure (resistance to air flow) by a factor of two. The only way to know if a room is getting the necessary air flow to heat and cool it: measure it.

The following steps are essential to successful high-performance HVAC installations:

- Provide clear specifications.
- Require that HVAC designers/installers collaborate with the architect to assure aesthetic locations for HVAC system elements inside the conditioned space.
- Conduct an onsite pre-installation briefing with the actual installers to ensure that they know the performance specifications they are responsible to meet.
- Require installers to comply with the *project specifications*, not just code minimums.
- Require installers to submit a final “performance measurement (commissioning) report” for every

home, such as the example shown in Table 4-3, which illustrates the range of performance factors that should be tested in order to ensure proper functioning of the system as a whole.

- Archive all reports.

Engaging Installers in Commissioning

Balancing delivered performance with installation cost requires knowing the system’s delivered performance – which requires conducting system performance measurements – i.e., commissioning. Historically, commissioning has not been required for residential projects. As a result, HVAC installation has been judged almost exclusively on cost, without relation to delivered system performance, i.e., operating efficiency and quality. Equipment efficiency ratings such as energy factor or coefficient of performance (EF and COP, respectively) are not substitutes for, nor should they be represented as measures of, the operating efficiency of the HVAC system as a whole.

Commissioning can be performed most effectively – and affordably – by the HVAC installers, while they are onsite. There are two notable side benefits of installers measuring the performance of their own work:

- Comparing measurements with high-performance targets provides quality control feedback that is otherwise absent from the industry – *and is the very best training for installers.*
- Measurement creates pride in workmanship. At <http://ring4.club/> you can see pride on the faces of California installers who install duct systems with zero leakage.

Installer-performed commissioning should be adopted as standard practice by all ZNE builders. This simple practice affords many benefits: training, quality management, cost control, risk reduction, and increased pride in workmanship.

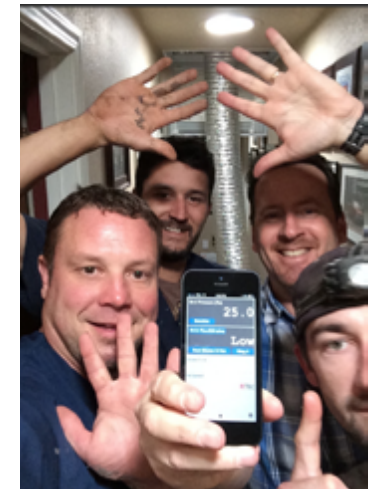

Energy Docs Home Performance

Table 4-3. Sample mechanical and enclosure commissioning report, Stockton, CA¹¹

MINI-SPLIT		
Daikin heat pump model RXS09LVJU, ¾ ton, SEER 24.5, HSPF 12.5		
Daikin ducted air handler FDXS09V95, 30' line set (no refrigerant adjustment required)		
Wired thermostat Daikin ENVi, web-enabled		
Duct leakage	13 CFM ₂₅ (hard to seal return)	
Duct leakage to outside	0 (not measurable, less than 9 CFM ₂₅)	
Check for refrigerant leaks	450 psi overnight test, 92-micron evacuation	
Static pressure	+7.7 Pa (hard to measure, poor plenum access)	
Fan watt draw	50 watts (high fan speed, 10-watt resolution)	
Total air flow	378 CFM (high fan speed, sum of the supplies)	
Room air flows (CFM)		
■ Living	104	
■ Kitchen	51	
■ Master bedroom	95	
■ Bedroom 2	56	
■ Bedroom 3	72	
Bedroom pressurization with air handler fan on high		
■ Master bedroom	+2.5 Pa	
■ Bedroom 2	+1.8 Pa	
■ Bedroom 3	+2.8 Pa	
ENERGY RECOVERY VENTILATORS		
Panasonic FV-04VE1 (2 units, each rated 40 CFM exhaust, 30 CFM supply, continuous operation)		
	Hall ERV	Living Room ERV
Static pressure	-21.0 Pa/+11.3 Pa	30.9 Pa/+9.6 Pa
Fan Watt draw	24.3 Watts	22.2 Watts

BATHROOM EXHAUST FANS		
Panasonic FV-11VQC5		
	Master Bath	Hall Bath
Rated fan speed (not selectable)	110 CFM	100 CFM
Humidity set-point	70% RH	70% RH
Occupancy timer set-up	turn off 5 minutes after occupant leaves	turn off 5 minutes after occupant leaves
Standby by Watt draw	0.6 Watts	0.7 Watts
Watt draw when operating	22.2 Watts	22.4 Watts
Static pressure	+19.3 Pa	+17.1 Pa
Measured air flow	111 CFM	109 CFM
ENCLOSURE		
Air infiltration	330 CFM ₅₀	
Air infiltration, ventilation system sealed	250 CFM ₅₀ , 1.53 ACH ₅₀	
House pressures when exhaust fans are on:		
■ Single bathroom fan	-12.8 Pa	
■ Both bathroom fans	-30.6 Pa	
■ Both bathroom fans + kitchen range hood	-36.2 Pa	
Non combustion appliances in conditioned spaces		
MEASUREMENT EQUIPMENT		
■ Fan Wattage – Kill-A-Watt P3 installed at electrical panel		
■ Air handler Wattage – Extech 380940 clamp-on watt meter, 10-watt resolution		
■ Exhaust air flow – The Energy Conservatory Exhaust Fan Flow Meter		
■ Supply air flow – The Energy Conservatory Flow Blaster power flow hood		
■ Manometer – The Energy Conservatory Digital pressure gauge, DG-700		

¹¹ This report was done for a Habitat for Humanity ZNE Demonstration home in Stockton, California. The full demonstration report is available at <https://www.etcc-ca.com/reports/zero-net-energy-production-builder-demonstration>.

HVAC RESOURCES

For live links to the online resources below, download the PDF version of this document at [pge.com/zne](https://www.pge.com/zne).

PG&E Stockton – Final Report, March 2017, Pacific Gas and Electric Company Zero Net Energy Production Builder Demonstration, Habitat for Humanity of San Joaquin County Dream Creek Subdivision, Stockton, CA, <https://www.etcc-ca.com/reports/zero-net-energy-production-builder-demonstration> (free download)

Measured Home Performance, Gas Technology Institute, Rick Chitwood and Lew Harriman, 2012. Free download at <https://www.gti.energy/measured-home-performance-a-guide-to-best-practices-for-home-energy-retrofits-in-california/> Paperback available for purchase on Amazon.

Revisions to Quality Management Products: Four Scopes of Work for High Performance Homes – NREL, National Association of Home Builders Research Center – covers excavation, foundations, framing, and HVAC, including recommended specification language, http://www.homeinnovation.com/trends_and_reports/featured_reports/scopes_of_work

Ace Installation Residential, Energy Code Ace – covers air sealing, insulation, HVAC, plumbing, and more [https://energycodeace.com/download/16520/file_path/field-List/2016 Installation Ace_Res_Complete Guide.pdf](https://energycodeace.com/download/16520/file_path/field-List/2016%20Installation%20Ace_Res_Complete%20Guide.pdf) [automatic download]

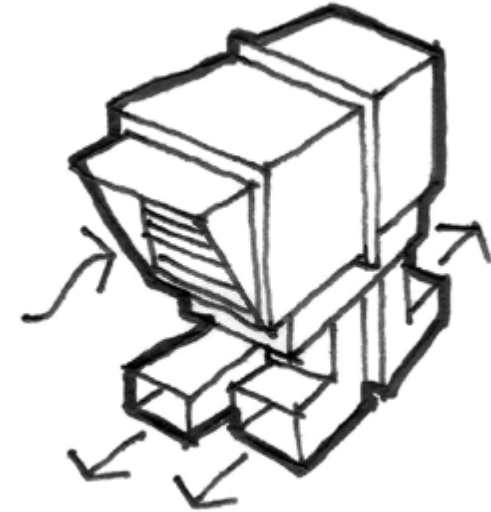

Unfortunately, nothing about HVAC sizing, design and installation is intuitive – it's not possible to assess delivered performance without performance measurements of the system in operation.

SECTION 5. WATER HEATING

WATER HEATING DESIGN FACTORS

Water heater efficiency. Title 24-2019 (in draft form as of the time of publication) offers three prescriptive water heating options – gas or electric heat pump, gas or propane tankless, or gas or propane storage tank. In each case, models labeled as Energy Star “Most Efficient” are good choices for ZNE homes. For a comparison of pros and cons of the different types, see *ZNE Primer*, page 21.

Hot water pipe layout. Route pipe as directly as possible to minimize pipe length. Often plumbers run piping at right angles, thinking it looks more professional, but this adds up to 40 percent more piping, which wastes water and energy and increases wait time for hot water. More below under “Hot Water Distribution.”

Pipe diameter. Install the smallest-diameter piping that meets the flow demand, to reduce water and energy waste and shorten hot water delivery time.

Recirculation controls (if applicable). When a compact layout isn’t feasible, install on-demand recirculation – see additional details below under “Hot Water Distribution.”

Piping insulation. Comply with code requirements and ensure careful and complete installation.

Appliance selection. Choose the most energy- and water-efficient clothes washer and dishwasher possible, using the resources listed below for guidance.

Shower and faucet flow rates. Specify showerheads with the lowest practicable flow rate (gallons per minute, or gpm) that will provide acceptable performance. CALGreen requires that the combined flow rate of all showerheads controlled by a single valve may not exceed 2.0 gpm @ 80 psi; however, it’s important to note that flow rate isn’t a good predictor of a satisfactory shower experience, and

showerheads with lower flow rates can provide greater energy savings without compromising performance. Be sure to consult credible, current reviews (e.g., on BuildingGreen.com) to assist in specifying models. Another important variable in shower performance is the height of the showerhead relative to the height of the person showering; if too great a distance between the two, the water droplets will cool too much before hitting the person. A good solution to ensure a happy shower for everyone is to specify adjustable-height fixtures whenever possible.

Heat Pump Water Heaters (HPWHs)

The State of California is rapidly moving to “decarbonize” the built environment, with increasing emphasis on electric space and water heating through heat pump technologies. In full electric residences,

HPWHs are roughly three times more efficient than electric resistance water heaters and are therefore a favored choice for ZNE homes. Although the first cost of the HPWH is typically \$700 to \$1,200 more than a resis-

tance water heater, its much higher efficiency offsets about 1 kW of PV for homes targeting ZNE — a savings of about \$3,000 at current prices, easily covering the higher cost of HPWH. If PV is not being

considered, the energy of savings of the HPWH will pay back in two to three years with typical usage patterns and electric rates in California.



WATER HEATING SYSTEM SPECIFICATIONS

Water heating specifications assume greater importance in overall home energy efficiency as envelope and HVAC loads diminish. In fact, water heating energy loads can surpass enclosure loads in highly-efficient homes in mild climates, and in multifamily projects. Table 5-1 shows the hot water systems of two production builders participating in ZNE demonstrations.

Table 5-1. Sample water heating system specifications

WATER HEATING		HABITAT FOR HUMANITY OF SAN JOAQUIN COUNTY	PULTEGROUP
■ WATER HEATER	water heater type, efficiency equipment location	tankless gas, 0.82 EF interior wall	condensing gas tankless, 0.95 EF garage
■ DHW DISTRIBUTION	insulation, pipe material recirculation fixtures pipe length	PEX in conditioned space NA low flow WH to last fixture 12', avg fixture run 8'	R-2 PEX included

HOT WATER DISTRIBUTION

While high efficiency, Energy Star water heaters are well understood, opportunities related to hot water distribution are less widely realized. Significant savings and service improvements can be gained by creating a floor plan with a compact layout of hot water-using fixtures: kitchen sink, tubs, showers, lavatory sinks, and clothes washer. A sample floor plan is shown below, in Figure 5-2. In this example, the longest run of hot water piping is 12 feet. Thus, hot water arrives extremely quickly, with very little waste, at the farthest hot water outlet, and there is no need for a recirculation system.

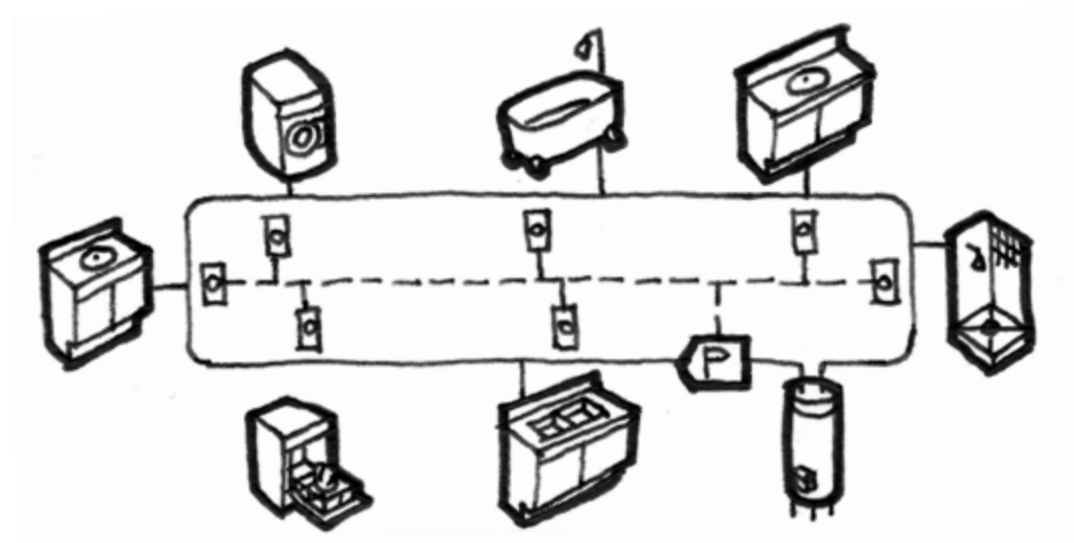
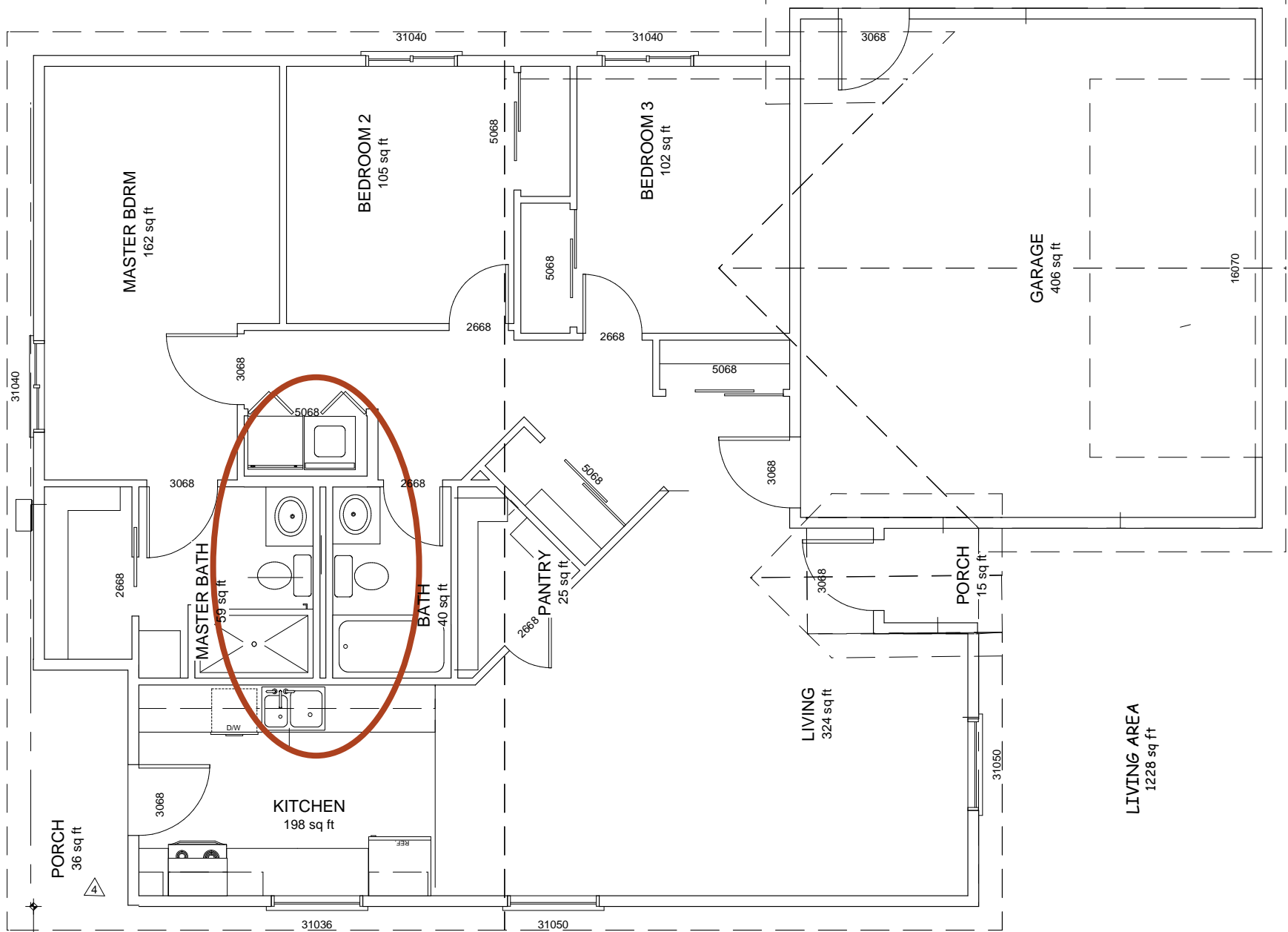

Figure 5-1. Compact hot water layout (Courtesy of Habitat for Humanity – San Joaquin)



California’s energy modeling software doesn’t reflect savings from compact plumbing layouts; however, a compact design saves water and energy every time you turn on the hot water tap. About 20% of the energy used to heat water is due to losses in the distribution system. A compact layout can prevent up to 75% of these losses, saving 15% of hot water energy consumption overall.¹²

In larger, more complex homes, where the plumbing layout is less compact, a hot water recirculation system may be desired. There are several types of approaches to recirculation; they are listed below, in decreasing order of efficiency:

- Push-button-activated – this is the most efficient, because hot water is only dispatched when it is actually needed.
- Proximity sensor-activated – this is somewhat less efficient because it will trigger the pump regardless of the reason for the occupant’s proximity to the sensor (for example, walking into the bathroom to get an aspirin).
- Timer-activated – this is considerably less efficient, because if the recirculation pump is set to run during all hours when someone might need hot water, it will run for many unneeded hours; it is also less flexible – e.g., if someone wants a shower after arriving home unusually late at night, they will need to wait for hot water.
- Continuous – this is highly inefficient, running the recirculation pump around the clock, when the actual need for hot water may be only a matter of an hour or so a day (requiring the pump to run for only a few minutes).

Figure 5-2. Water distribution manifold and installation schematic (Courtesy of Habitat for Humanity – San Joaquin)

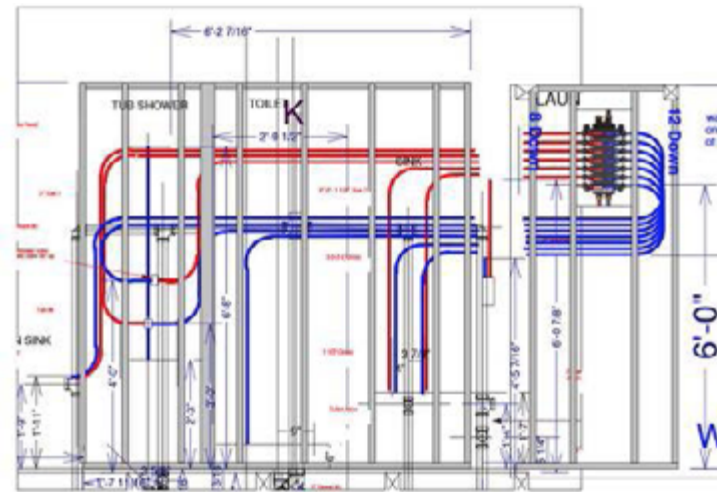

Wall 5 & 11 showing water piping



A compact layout is, of course, the least-cost approach to providing hot water quickly to all hot water outlets. A key feature of a compact layout is locating the water heater adjacent to all the hot water draw points – typically in the center of the home. Figure 5-1 shows the water heater (a tankless, direct-vent, sealed-combustion unit) installed above the clothes washer in the laundry closet; the distribution manifold is installed on the same wall. Figure 5-3 shows the manifold installation along with the installation schematic, which was developed to help simplify installation, saving time and money.

¹² Gary Klein, Gary Klein and Associates, personal communication, 2018.

QUALITY INSTALLATION

Activities essential to successful, high-quality water heating system installation include:

- Developing a design with the most compact possible layout of hot water system components.
- Providing clear specifications.
- Conducting a pre-installation briefing of onsite installers as to the quality expectations.
- Maintaining close onsite supervision during installation, assuring the shortest piping runs possible.



WATER HEATING RESOURCES

For live links to the online resources below, download the PDF version of this document at pge.com/zne.

Gary Klein & Associates – videos, articles, classes,
<http://www.garykleinassociates.com/>

Energy Star Water Heaters, https://www.energystar.gov/products/water_heaters – select Energy Star “Most Efficient”

Consortium for Energy Efficiency, <http://www.cee1.org/> – the most efficient models are designated as Tier 3

Enervee.com, <https://enervee.com/> – the most efficient models are rated 90-100

WaterSense New Home Specification Guide for Efficient Hot Water Delivery Systems, US Environmental Protection Agency, <https://www.epa.gov/sites/production/files/2017-01/documents/ws-homes-hot-water-distribution-guide.pdf> – on-demand hot water recirculation system design guidance

**Water heating specifications
assume greater importance
in overall home energy
efficiency as envelope and
HVAC loads diminish.**



SECTION 6. ELECTRIC LOADS & PRODUCTION

ELECTRIC LOADS

Because of highly energy-efficient envelopes and mechanical systems, electric loads can represent a higher fraction of energy use in ZNE homes than in their merely code-compliant counterparts. Thus, despite Title 24's strict regulation of many aspects of lighting design, selection of fixtures and appliances nevertheless deserves attention. This is particularly true because, while conscientious design and construction can effectively control envelope and HVAC-related loads, electric loads are very occupant-driven and occupant-specific, varying by a factor of five or more among relatively similar households and home sizes.¹³ While as the builder you have limited opportunities to curb electricity use (homeowners have many devices that get plugged in after you are gone), there are some key uses over which you have some control. Chief among these are lighting and appliances.

Exceeding Title 24's lighting requirements won't show up as an improvement in a code compliance energy model, but it can reduce operating energy use. Measures to consider include:

- Specifying 100% LED fixtures
 - Emphasizing lighting *quality* – selecting locations, fixtures, and lamping options to most effectively meet functional needs and reinforce the architectural design, while eliminating excess or ill-placed fixtures
 - Avoiding recessed cans in insulated ceilings
- Refrigerators, clothes dryers (especially for large families), and other appliances

can represent significant electric loads. If you provide appliances in your homes, consider choosing models rated as Energy Star “Most Efficient,” CEE1.org Tier 3, or 90+ on Enervee.com.

ELECTRIC SPECIFICATIONS

Table 6-1 shows the electric loads of two production builders participating in the PG&E ZNE demonstration.

Table 6-1. Sample electric load-related specifications

ELECTRIC LOADS		HABITAT FOR HUMANITY OF SAN JOAQUIN COUNTY	PULTEGROUP
■ LIGHTING	type controls	100% LED	mostly LED, some CFL color controls in kitchen
■ APPLIANCES	fridge cooking dishwasher, washer, dryer washer dryer	ENERGY STAR fridge electric cooking not provided	ENERGY STAR fridge induction stove ENERGY STAR washer gas dryer
■ OTHER	indicator lights, switches, etc	indicators for garage and porch lights; power disconnect for heat pump and water heater	

¹³ Chris Calwell, Ecos Consulting, personal communication, April 2018.

RENEWABLE ELECTRICITY PRODUCTION

Experienced ZNE designers and builders have found that when they design for ZNE from the ground up, they minimize their PV needs, have ample space for it, and savings accrued from efficiency in other aspects of design cover – or nearly cover – the expense of the PVs. PVs are also available at little or no up-front cost through lease and other finance options such as power purchase agreements (PPAs).

The bottom line is a ZNE home – a house with the added value of producing its own energy – that costs the same as a non-ZNE home.

A ZNE home – with its own renewable energy system – can cost the same as a home that barely meets code.

Table 6-2. ZNE homes with PV system sizes

Builder	Location	CA Climate Zone	Heating Degree Days	Cooling Degree Days	Home Size (sq.ft.)	PV Array Size (kW) ¹⁴
Habitat for Humanity of San Joaquin County	Stockton, CA	12	2,702	1,700	1,200	3.2
CHISPA	Greenfield, CA	4	2,454	257	1,167	2.5
Blu	Loomis, CA	11	3,149	1,354	1,869	4.58
PulteGroup	Brentwood, CA	12	2,621	1,226	2,344	4.62
Meritage	Hayward, CA	3	3,071	183	2,061	4.05
De Young	Clovis, CA	13	2,443	1,599	2,024	5.58



Botanica, Brentwood, CA
SDG Architects, PulteGroup, 2016
PG&E photo

¹⁴ PV array calculated to meet ZNE using CA time-dependent valuation rules. Installed sizes in some cases differ.

ELECTRIC LOAD RESOURCES

For live links to the online resources below, download the PDF version of this document at pge.com/zne.

Residential Lighting, California Lighting Technology Center, UC Davis (this document may require some updates to reflect 2019 code), http://energycodeace.com/content/resources-ace/file_type=application-guide

Liberty Lighting Guidelines for Zero Net Energy Communities, California, <https://cltc.ucdavis.edu/publication/liberty-lighting-guidelines-zne-communities>

www.enervee.com – a frequently-updated resource providing energy efficiency ratings and energy and purchase costs for appliance and electronics

Energy Star, <https://www.energystar.gov/products/appliances>

Consortium for Energy Efficiency (CEE) – listings of efficient heating and cooling systems, appliances, water heaters, lighting, swimming pool pumps and pump controls, and consumer electronics, <http://www.cee1.org/content/cee-program-resources>

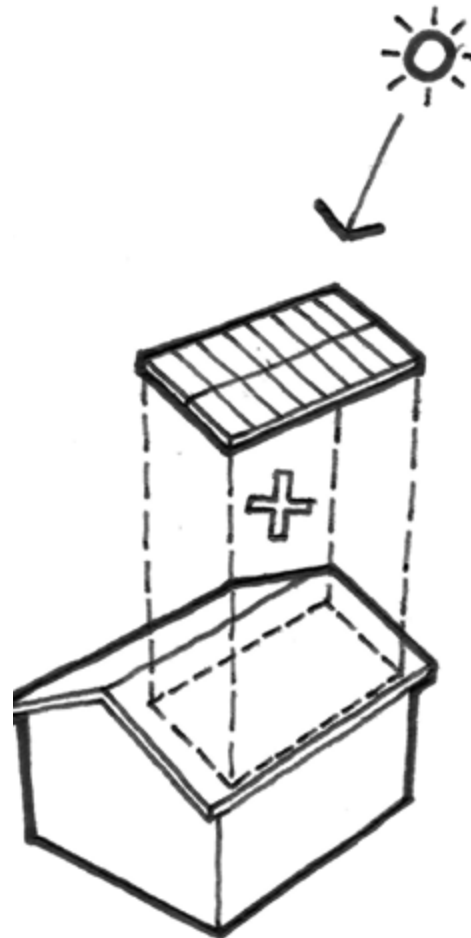

Glossary

- **Advanced Framing:** A set of practices that reduce the amount of framing material in order to increase energy efficiency and lower cost.
- **Blower Door:** A powerful fan temporarily mounted into the frame of an exterior door. The fan pulls air out of the house, lowering the air pressure inside, causing outside air pressure to flow through the unsealed cracks and openings. Blower door tests determine the air infiltration rate of a building.
- **Climate Zone:** Various climate regions distinguished based on heating degree-days, average temperatures, precipitation, insolation, and other factors. These regions are used by Building America to determine appropriate building practices to achieve the most energy savings in a home.
- **Cool Roof:** Roofing product with high solar reflectance (SR) and thermal emittance (TE) properties, which help reduce electricity used for air conditioning by lowering roof temperatures on hot, sunny days. *Solar reflectance* refers to a material's ability to reflect the sun's solar energy back into the atmosphere. *Thermal emittance* provides a means of quantifying how much of the absorbed heat is rejected for a given material. Both properties are measured from 0 to 1, and the higher the value, the 'cooler' the roof.
- **Framing Factor:** The percentage of a wall assembly that is comprised of framing members instead of insulation. Reducing framing factors reduces material costs and increases envelope thermal efficiency
- **Mini-split:** A favorably efficient indoor heating and cooling system with two main components- an outdoor compressor/condenser and an indoor air handling unit.
- **Radiant Barrier:** a highly reflective material that reflects radiant heat rather than absorbing it, usually installed in attics to reduce summer heat gain and reduce cooling costs. (Note: they do not reduce heat conduction like thermal insulation materials)
- **Thermal Barrier:** Portion of the building envelope meant to slow the movement of thermal energy between interior conditioned space and exterior unconditioned space
- **Title 24:** "California Title 24 (Part 6) Building Energy Efficiency Standards" aim to ensure new and existing buildings achieve energy efficiency and preserve outdoor and indoor environmental quality. These measures are listed in the California Code of Regulations, and the responsibility for adopting, implementing, and updating building energy efficiency falls to the California Energy Commission. Local city and county enforcement agencies have the authority to verify compliance with applicable building codes, including energy efficiency.
- **Zero Net Energy:** A zero net energy building produces as much renewable electricity as it consumes over the course of a year. ZNE buildings can be assessed based on a variety of energy metrics including site energy, source energy, and TDV.



Acronyms

ACH ₅₀	air changes per hour at 50 Pa
CDs	contract documents
CEC	California Energy Commission
CFL	compact fluorescent lamp
CFM	cubic feet per minute
CPUC	California Public Utilities Commission
CZ	climate zone
ERC	energy recovery ventilators
HVAC	heating, ventilation, and air conditioning
LED	light emitting diode
Pa	Pascal (unit of pressure)
PV	photovoltaics
RH	relative humidity
SHGC	solar heat gain coefficient
ZNE	zero net energy



**This Guide is a
concise summary
of key actions and
guidance to assist
in achieving a
smooth transition
to ZNE performance.**